

Automatic control in medicine and fuzzy logic as an universal method for analyzing physiological networks

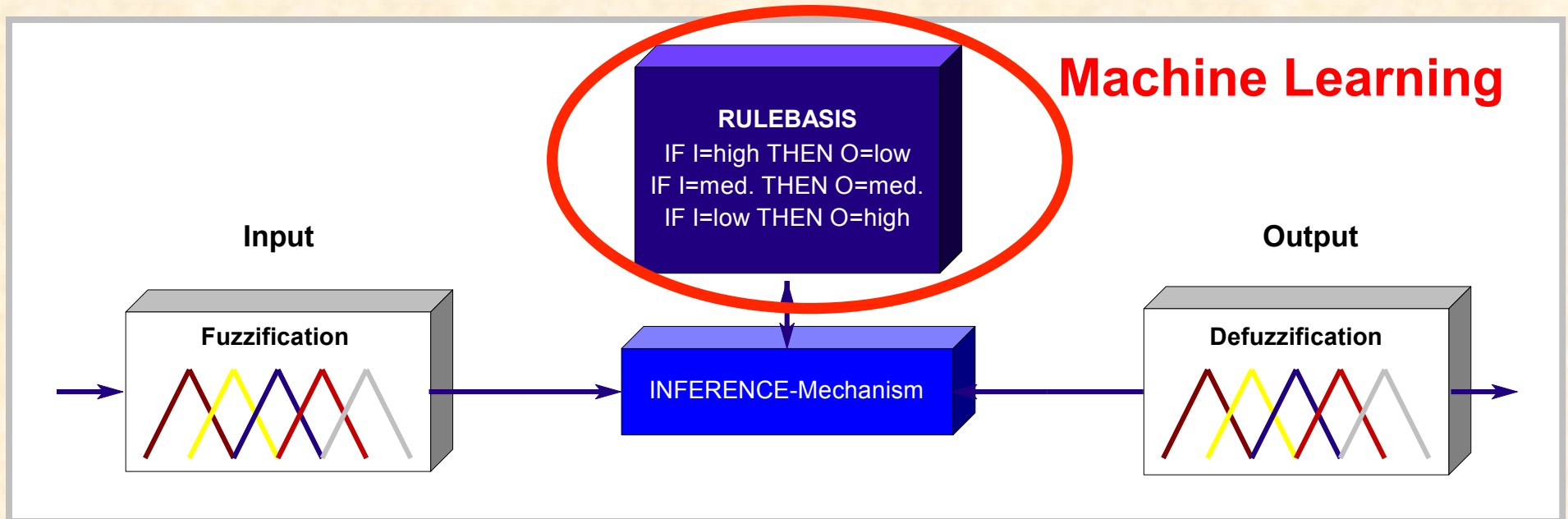



ncbi.nlm.nih.gov

How To

PubMed fuzzy

Create RSS Create alert Advanced

Format: Summary Sort by: Most Recent Per page: 20 Send to

See [fuz.L \(FUZZY\) fuzzy planar cell polarity protein L homeolog](#) in the Gene database
[fuzzy](#) in [Xenopus laevis](#) [Bactrocera dorsalis](#) [Ceratitis capitata](#) [All 3 Gene records](#)

Search results

Items: 1 to 20 of 9015

<< First < Prev Page 1 of 451 Next > Last >>

ncbi.nlm.nih.gov

How To

PubMed machine learning

Create RSS Create alert Advanced

Format: Summary Sort by: Most Recent Per page: 20 Send to

Search results

Items: 1 to 20 of 17081

<< First < Prev Page 1 of 855 Next > Last >>

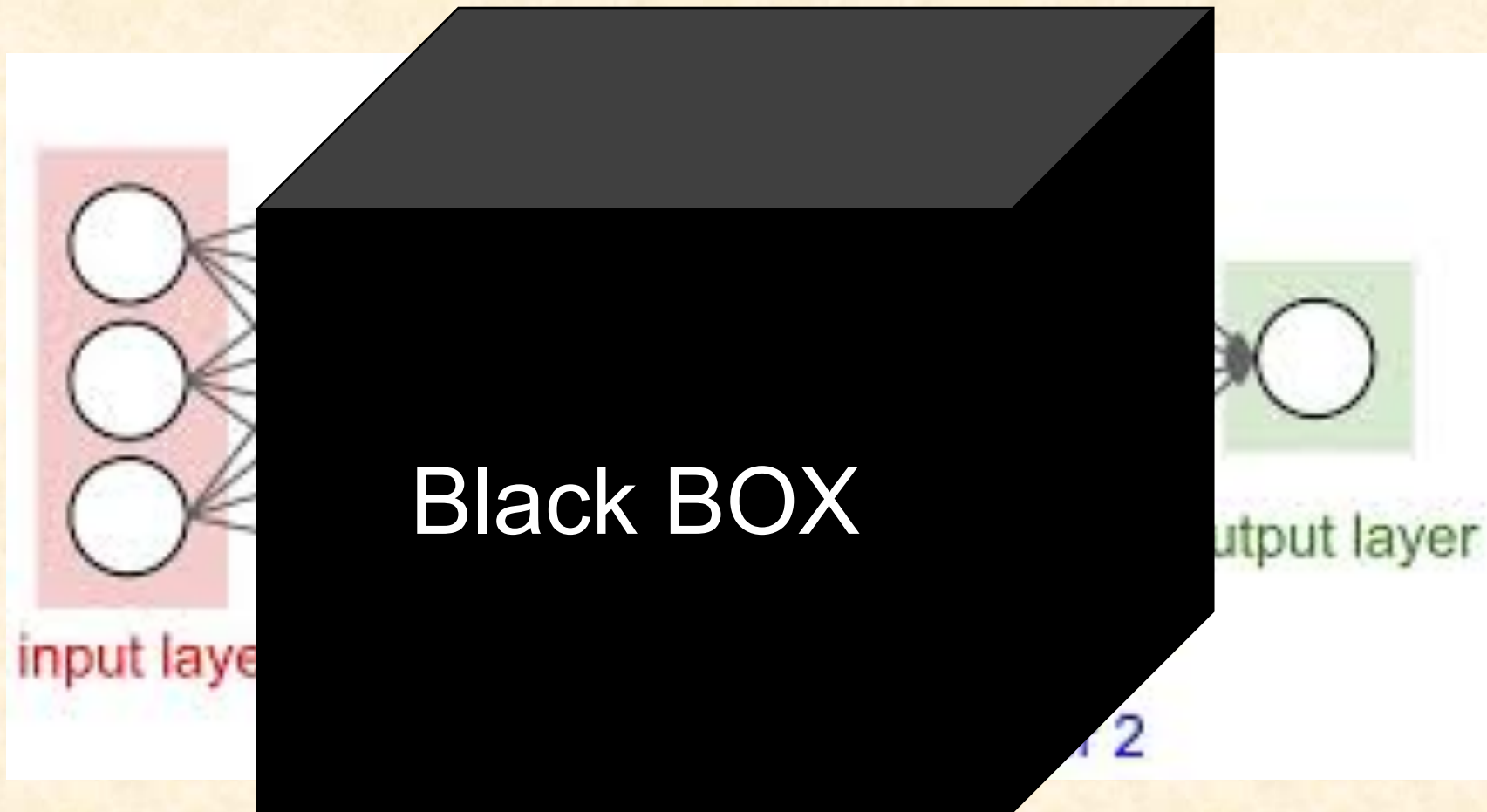

MYOELECTRIC PROTHESIS CONTROL

bipolar registration of el. potentials

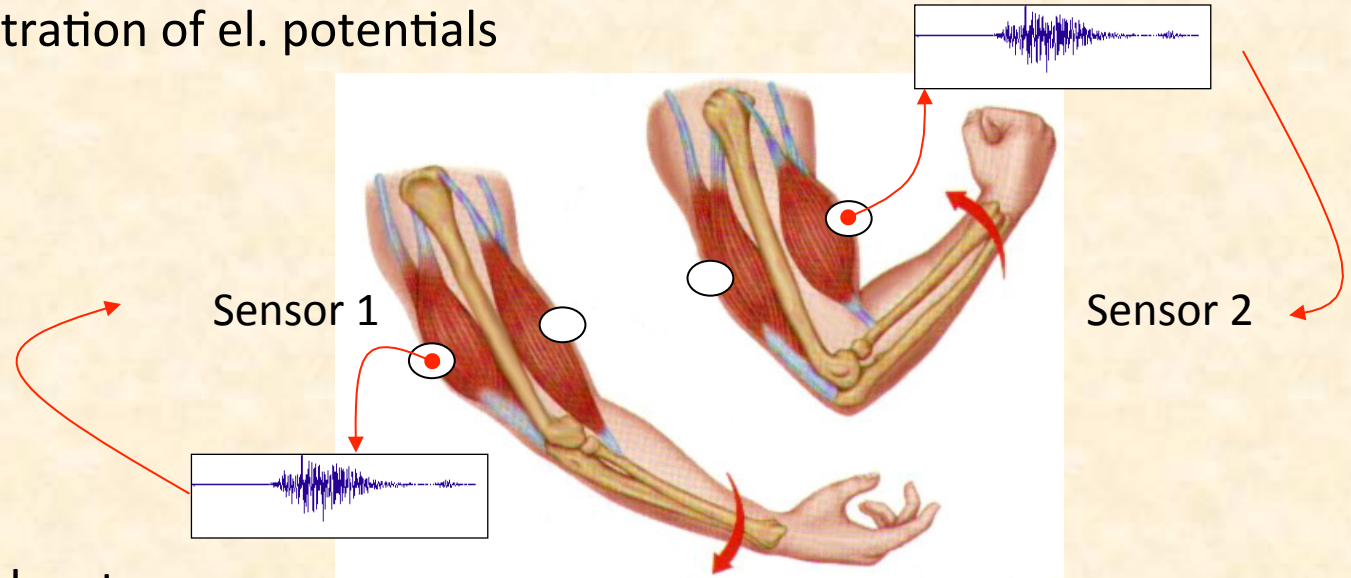

Control system

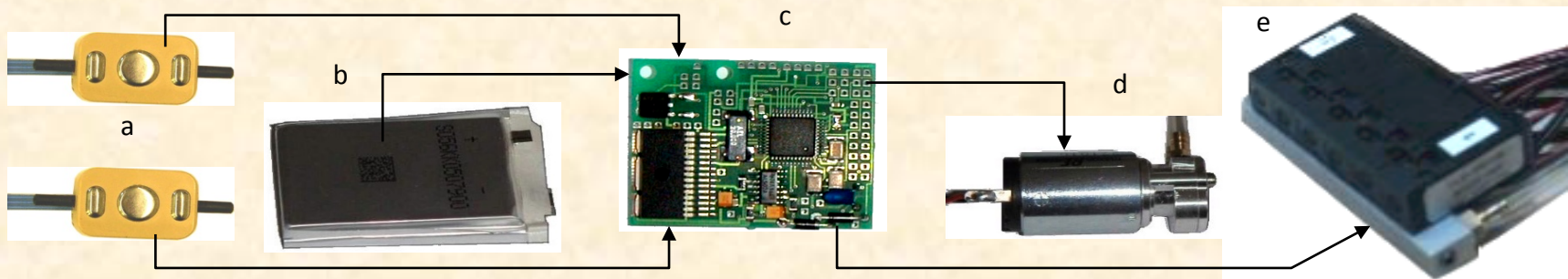

Myoelektroden (a), Li-Ion-Akku (b), Steuerungselektronik (c), Pumpe (d), Ventile (e)

Motivation: physiological networks

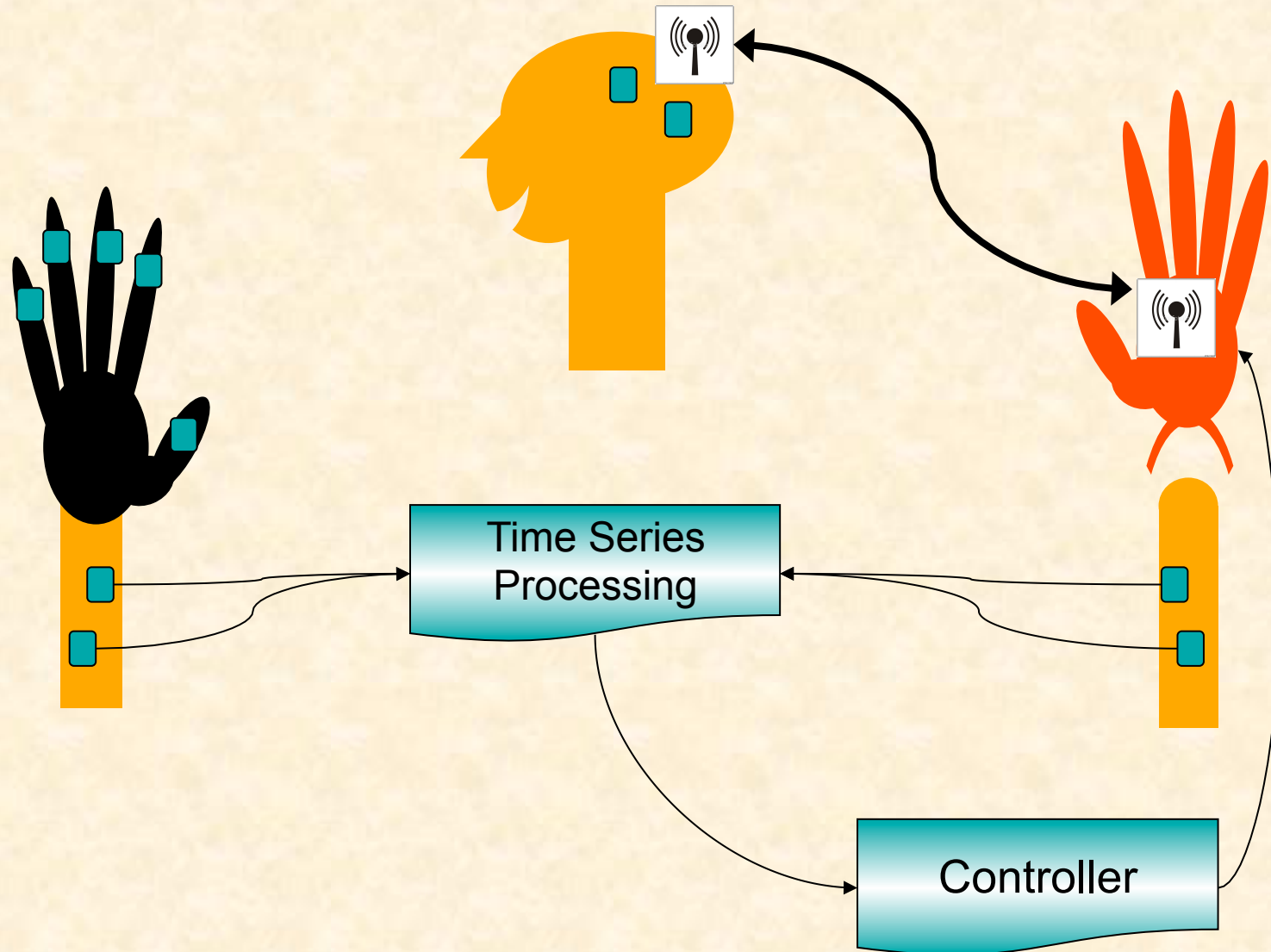

Systems design

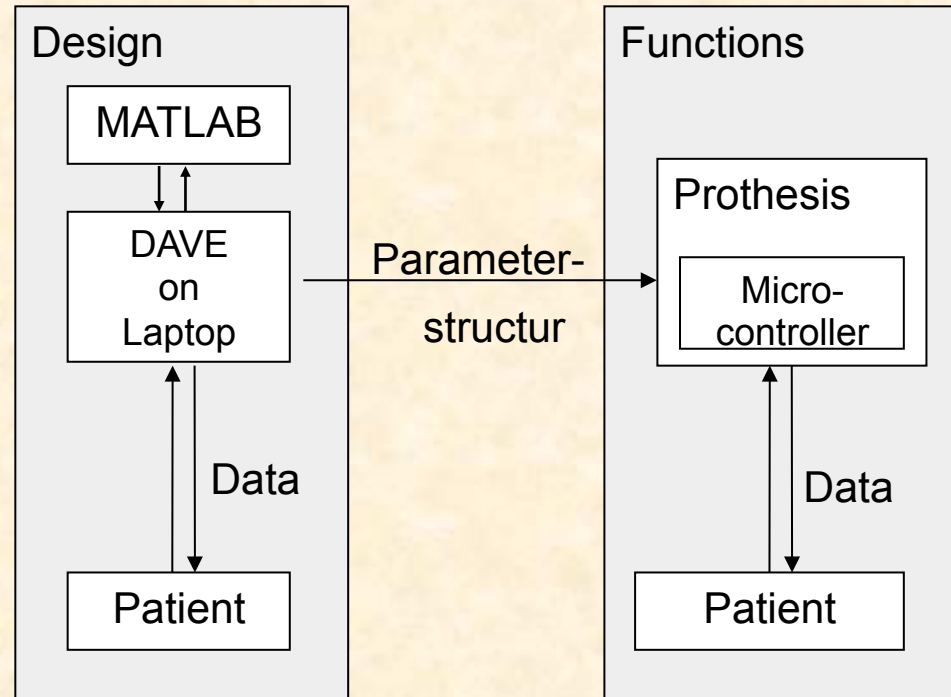

Design:

- **Adaptation on the patients requirements**
- **Input of experts knowledge**
- **Automatical optimization**

Functions:

- **Source code transfer on the Microcontroller**

Hannover/Karlsruhe (asb). Einen schnellen und einfachen Zugang in das Internet bietet die Karlsruher fun communications auf der CeBIT an: „Wir stellen smartID vor. Es ermöglicht die Anmeldung zu Internet-Anwendungen über MasterCard und man muss sich nicht merken, das übernimmt Annette Höllebrand, fun communications.

Giant hand

CeBIT
Join the vision

artCard bietet zudem eine Versicherung gegen feindliche Übernahme im Spiel das automati-

zeit geht das Karlsruhe-Steuerrecht im Steuerrecht ein. Immer mehr Unternehmen wickeln aus Kostengründen den Austausch von Rechnungen mit ihren Geschäftspartnern elektronisch ab. Für Ausdrucken, Kuvertieren, Porto, Versand und Archivieren fallen je nach Grad der Automatisierung Kosten zwischen zwei bis zehn

Euro an. Auch beim Eingang der Rechnungen entstehen normalerweise erhebliche Kosten. Die in der elektronischen Rechnung ausgewiesene Umsatzsteuer kann aber nur dann als Vorsteuerabzug geltend gemacht werden, wenn die Rechnung mit einer qualifizierten elektronischen Signatur versehen ist und sich die Partner zuvor über diesen Abrechnungsmodus geeignet haben. Die Lösung heißt fun SignFactory on Demand: Mit ihr können Unternehmen elektronisch erstellte und übermittelte Rechnungen im PDF-Format mit der Signatur versehen werden.

Höllebrand: „Die Lösung ist zum Beispiel für Telefongesellschaften oder Internet-Powerseller, die eine große Anzahl an Rechnungen stellen, interessant.“ Passend dazu gibt es die rechtssichere Prüfungs- und Archivierungs-Software PDF-Faktura. Einen einheitlichen Zugang zu nahezu allen deutschen Banken bietet Bank'n'Bonus on Demand.

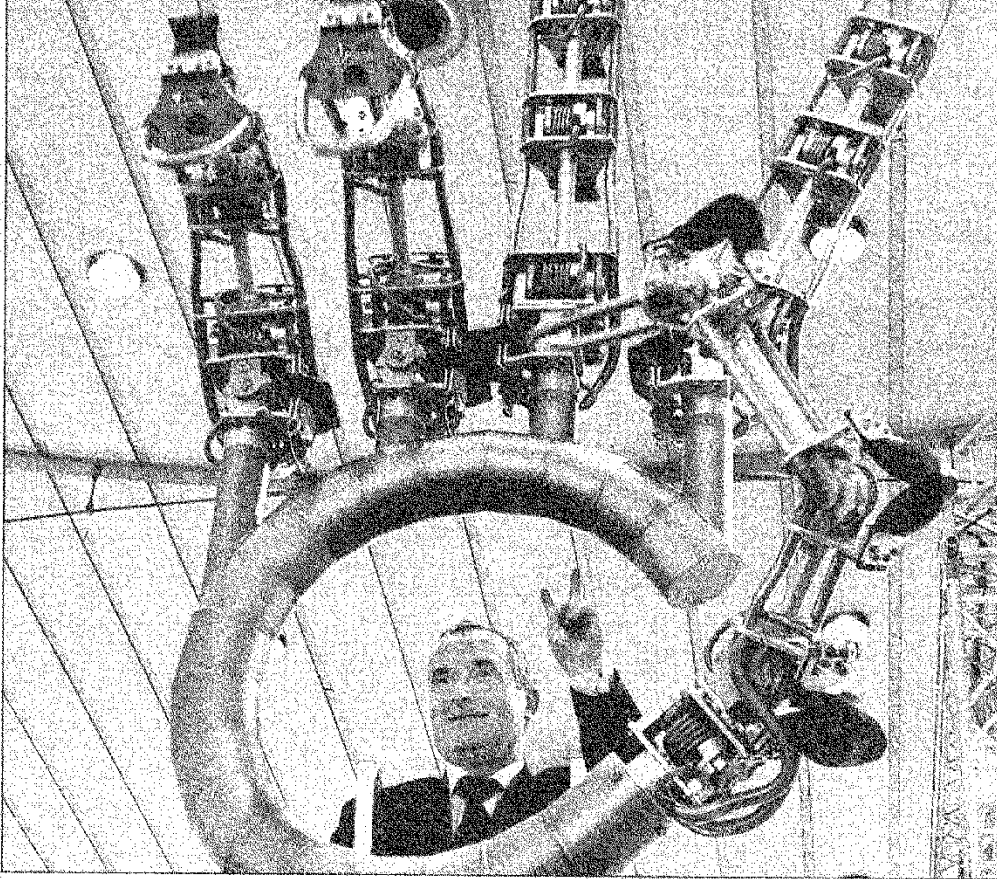

EIN BLICKFANG auf der CeBIT ist die weltgrößte Roboterhand aus Karlsruhe. Georg Bretthauer vom Forschungszentrum Karlsruhe demonstriert ihre Fähigkeiten. Foto: Forschungszentrum

Riesenhand kommt aus Karlsruhe

Hannover/Karlsruhe (asb). Mit einem Meter Durchmesser zehn Mal größer aber genauso beweglich wie eine Menschenhand: Neben den üblichen Greifmustern kann die künstliche Riesenhand, die im Forschungszentrum Karlsruhe entwickelt wurde, die Buchstaben des Fingeralphabets für Taubstumme darstellen.

„Die Riesenhand ist ein Spin-off unserer täglichen Arbeit“, freut sich Georg Bretthauer, Leiter des Instituts für Angewandte Informatik im Forschungszentrum. „Wir ha-

ben sie entwickelt, um das Potenzial der neuen Technologie für die Kommunikation an der Schnittstelle Mensch-Technik zu demonstrieren. Gleichzeitig ist damit ein eigenständiges Kunstwerk entstanden“, erklärt Bretthauer.

Die technische Grundlage sind so genannte Fluidaktoren. Die einzelnen Funktionselemente, die Aktoren, bestehen jeweils aus einer Kammer, die über einen Steuerkanal mit Luft befüllt wird. Die Kammer verformt sich beim Befüllen und erzeugt damit eine mechanische Bewegung. Fluidaktoren werden meist in Mikroausführung für Anwendungen in der Protetik, der Automatisierung und der Robotik eingesetzt.



Lotfi Zadeh (*1921)

Fuzzy set theory (1965)

Fuzzy logic (1973)

Natural Language



- Consider:
 - “Australian are tall” → what is tall?
 - “Australian are very tall” → what does this differ from tall?
- Natural language (like most other activities in life and indeed the universe) is not easily translated into the absolute terms of 0 and 1.

“false”

“true”

1. Motivation

Fuzzy logic as a universal tool for modeling / analyzing of biological transfer functions

- Expression of fuzzy knowledge in words
- Expert knowledge in variables and relations
- Nonlinear behaviour
- „Fuzzy“ as a characteristic of biological systems

Conception of Fuzzy Logic



- Many decision-making and problem-solving tasks are too complex to be defined precisely
- However, people succeed by using imprecise knowledge
- Fuzzy logic resembles human reasoning in its use of approximate information and uncertainty to generate decisions.

Fuzzy Logic



- An approach to uncertainty that combines real values $[0...1]$ and logic operations
- Fuzzy logic is based on the ideas of fuzzy set theory and fuzzy set membership often found in natural (e.g., spoken) language.

2. Fuzzy Basics

2. Fuzzy Sets

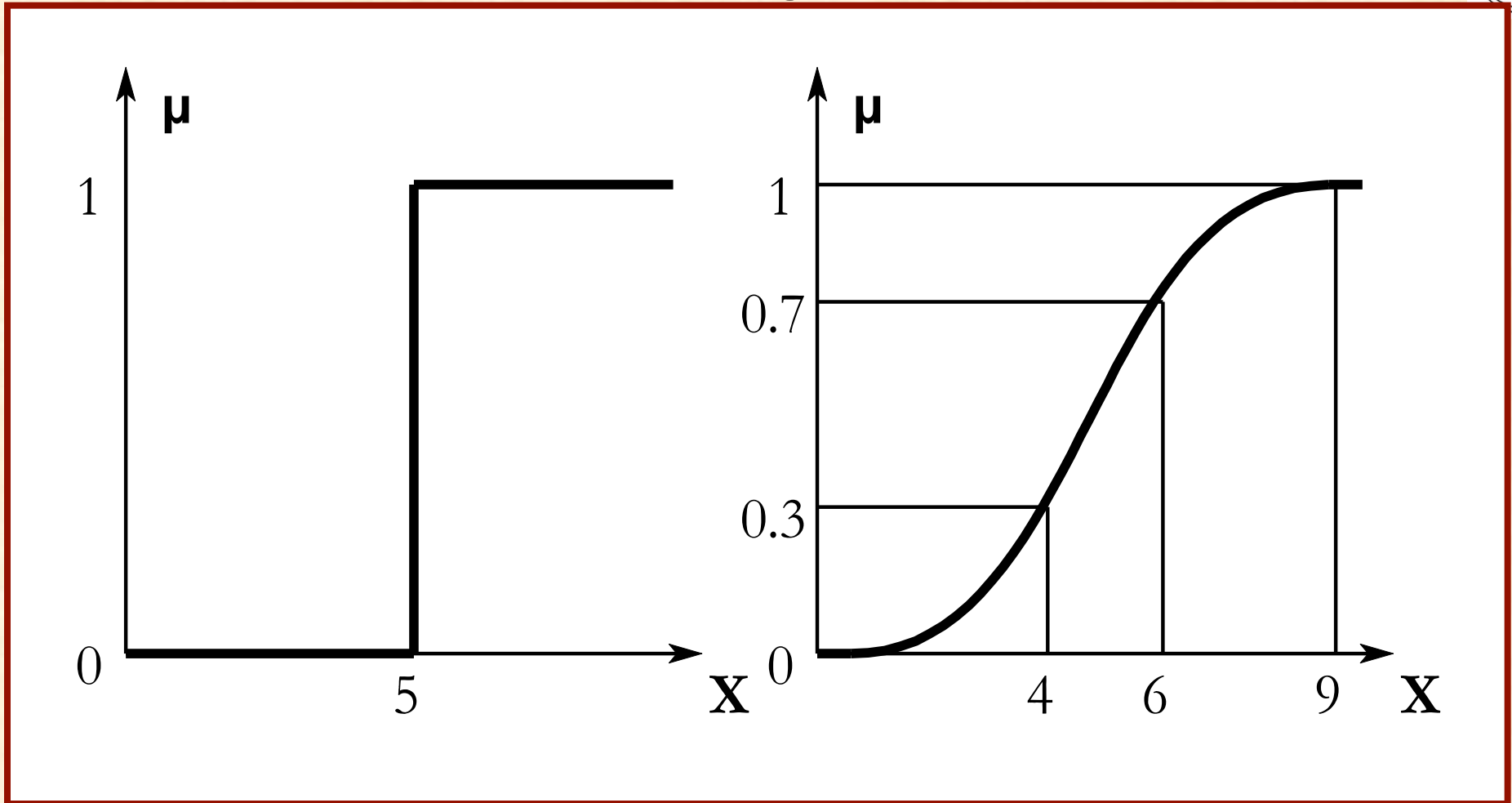

Modelling of set X as a crisp one (left) and as a fuzzy set (right)

Crisp set vs. Fuzzy set

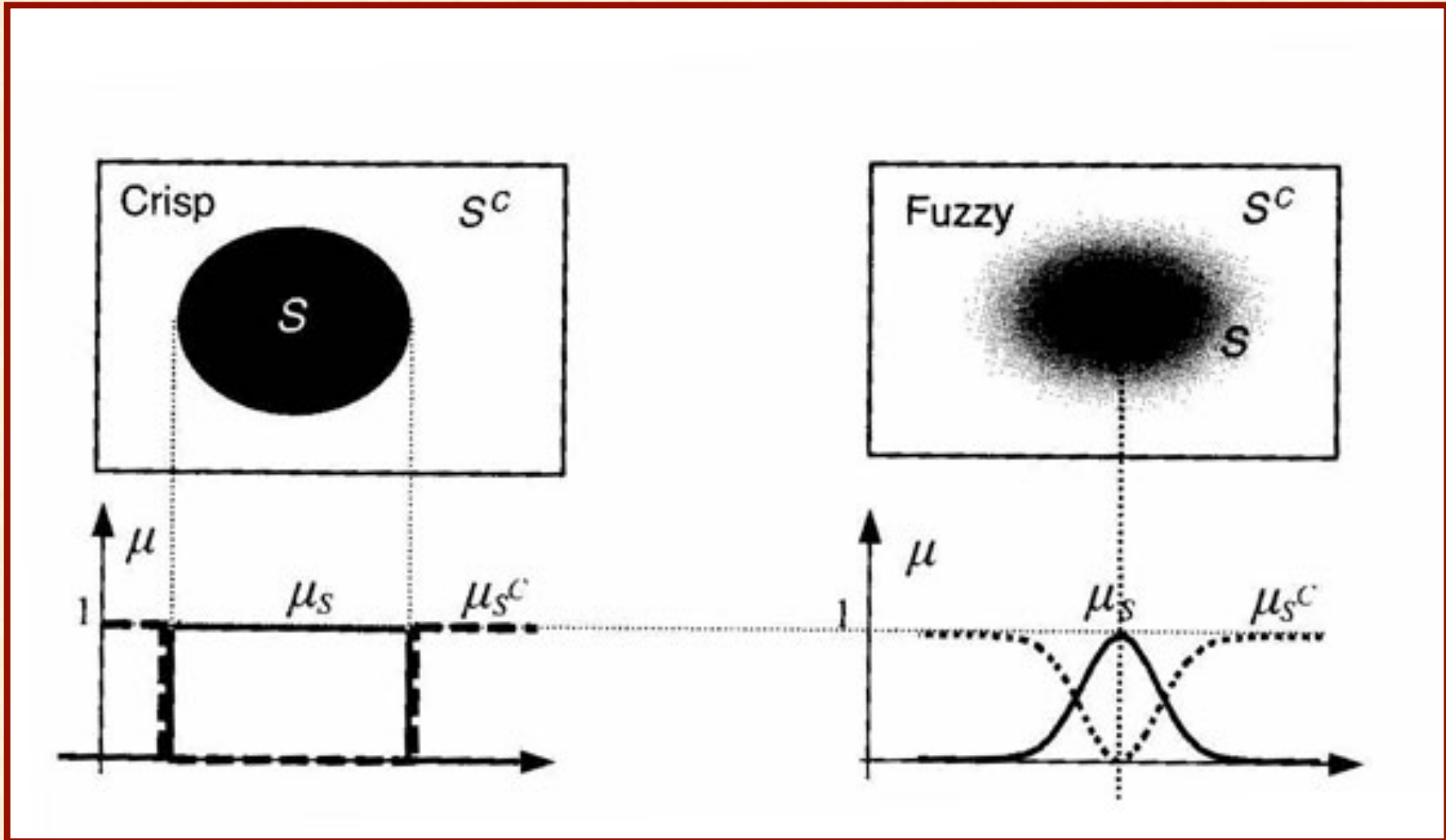

2. Fuzzy Sets

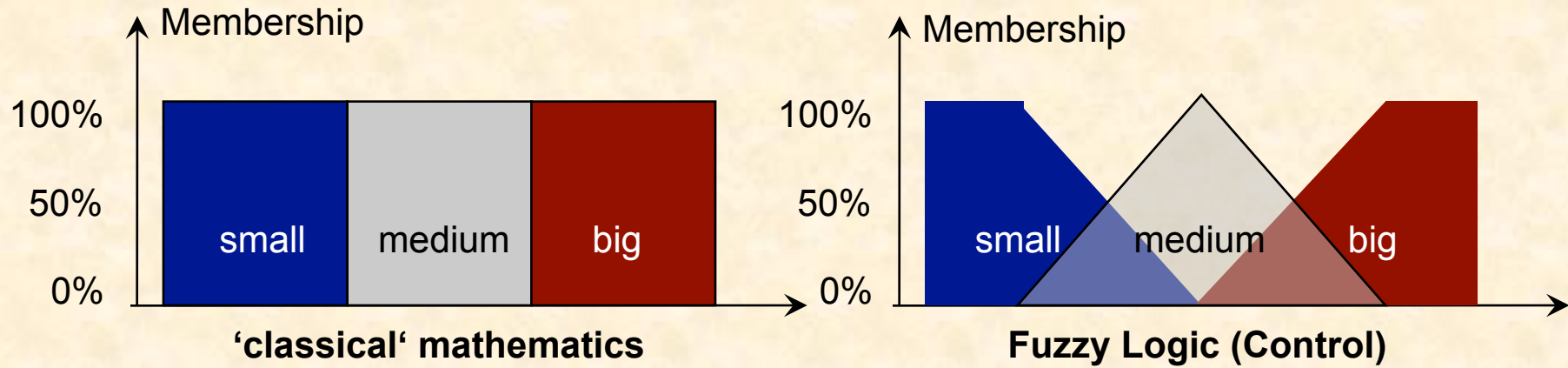

Some misapprehensions !

Definitions: Fuzzy Set, Membership Function



A sorted number of pairs

$$F := \left\{ (x, \mu_F(x)) \mid x \in X \right\}$$

is defined as **Fuzzy-Set in X**.

The relation

$$\mu_F : X \rightarrow [0,1]$$

is defined as **Membership-function**.

The membership function assigns every element x of basic set X a **degree of membership** $\mu_F(x)$

The single pair $(x, \mu_F(x))$ is identified as **Singleton**.

Definitions: Height, normal Fuzzy Set

Is F a fuzzy set in X , so is

$$H(F) = \max_{x \in X} \mu_F(x)$$

the **Height** of F .

F is defined as a **normal fuzzy set**, if

$$H(F) = 1$$

otherwise **subnormal fuzzy set**.

Definitions: Support

Is F a Fuzzy Set in X , so

$$\text{supp}(\mu) = S(F) = \{x \in X \mid \mu_F(x) > 0\}$$

is defined as **Support** of F .

Definitions: Tolerance

Is F a fuzzy set in X , so

$$T(F) = \{x \in X \mid \mu_F(x) = 1\}$$

is defined as **Tolerance** of F .

Support vs. Tolerance

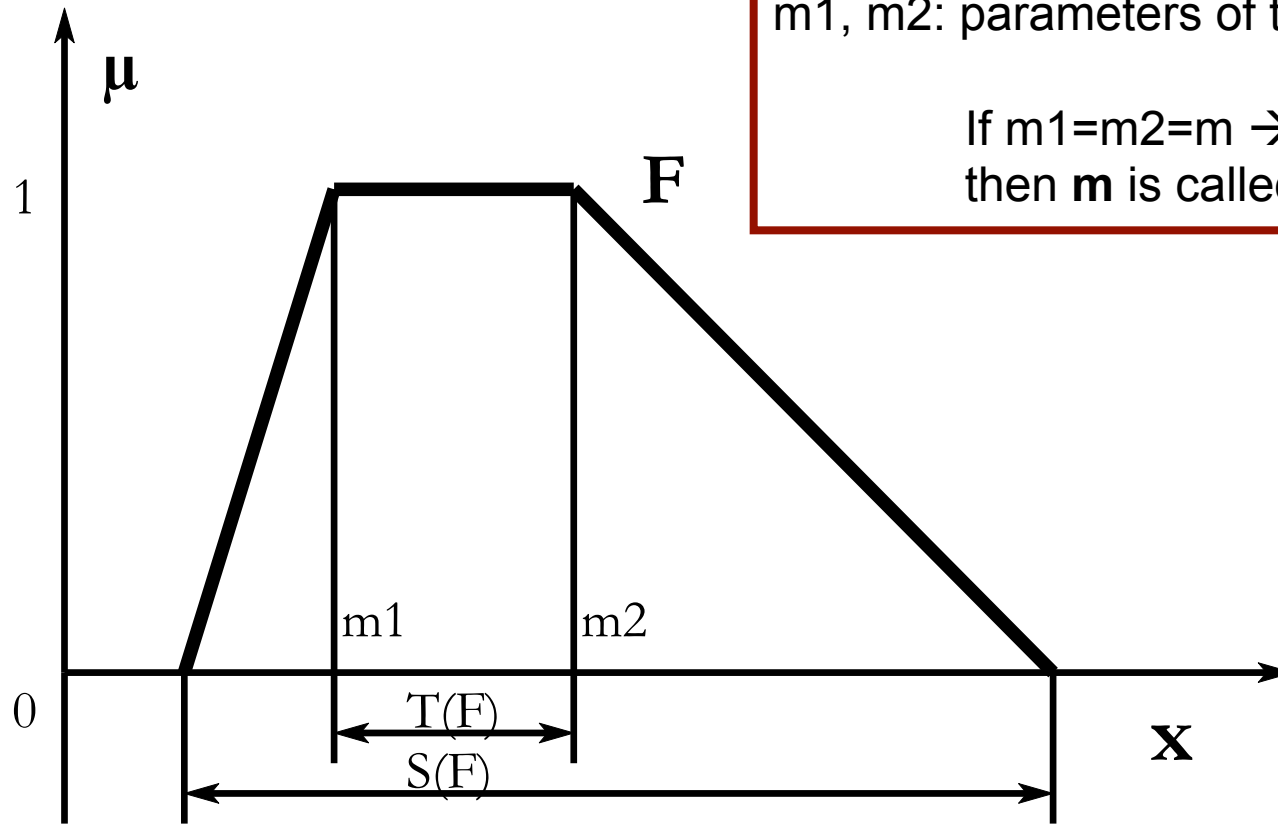

m_1, m_2 : parameters of the membership function

If $m_1=m_2=m \rightarrow$ triangle membership function
then m is called **mode**

Support $S(F)$ and Tolerance $T(F)$ of a fuzzy set F with trapeziod membership function

Types of membership functions

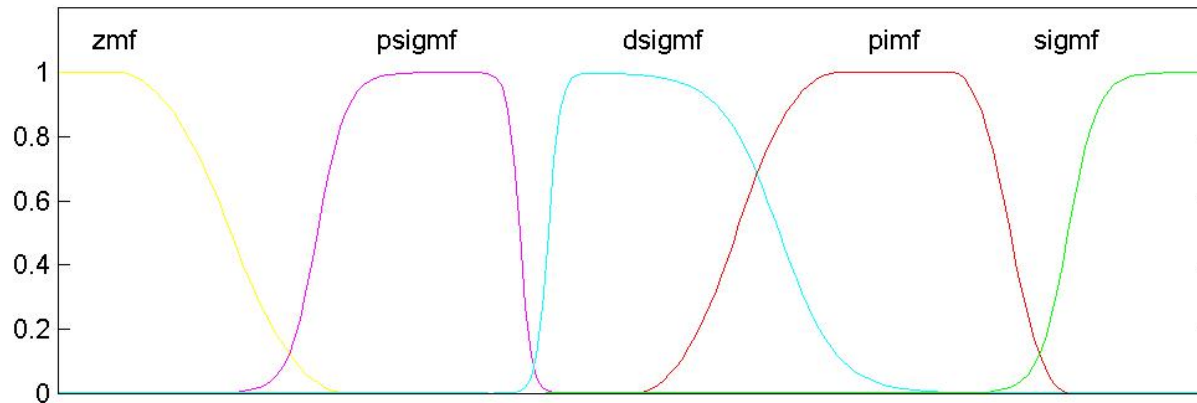
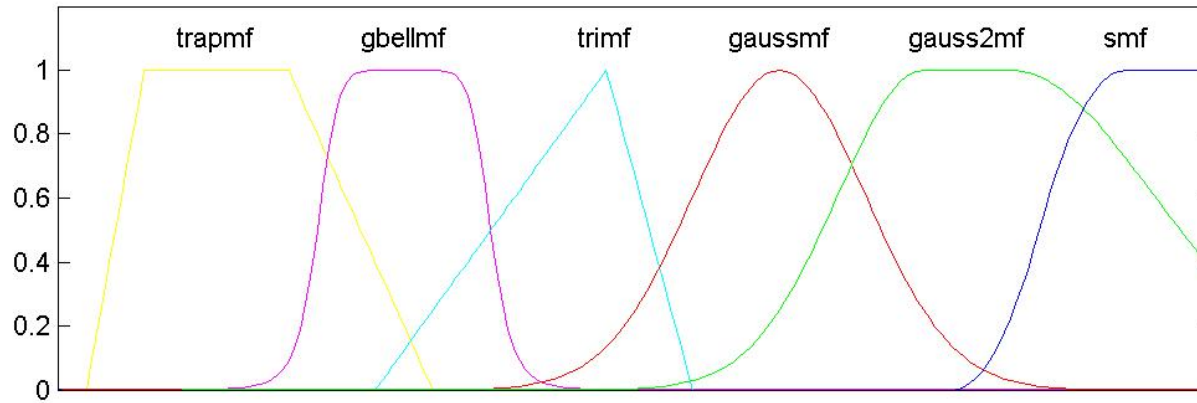

Fuzzy Set Operations



Union, intersection:

$$f: [0,1] \times [0,1] \rightarrow [0,1]$$

Complement:

$$f: [0,1] \rightarrow [0,1]$$

Fuzzy Set operations

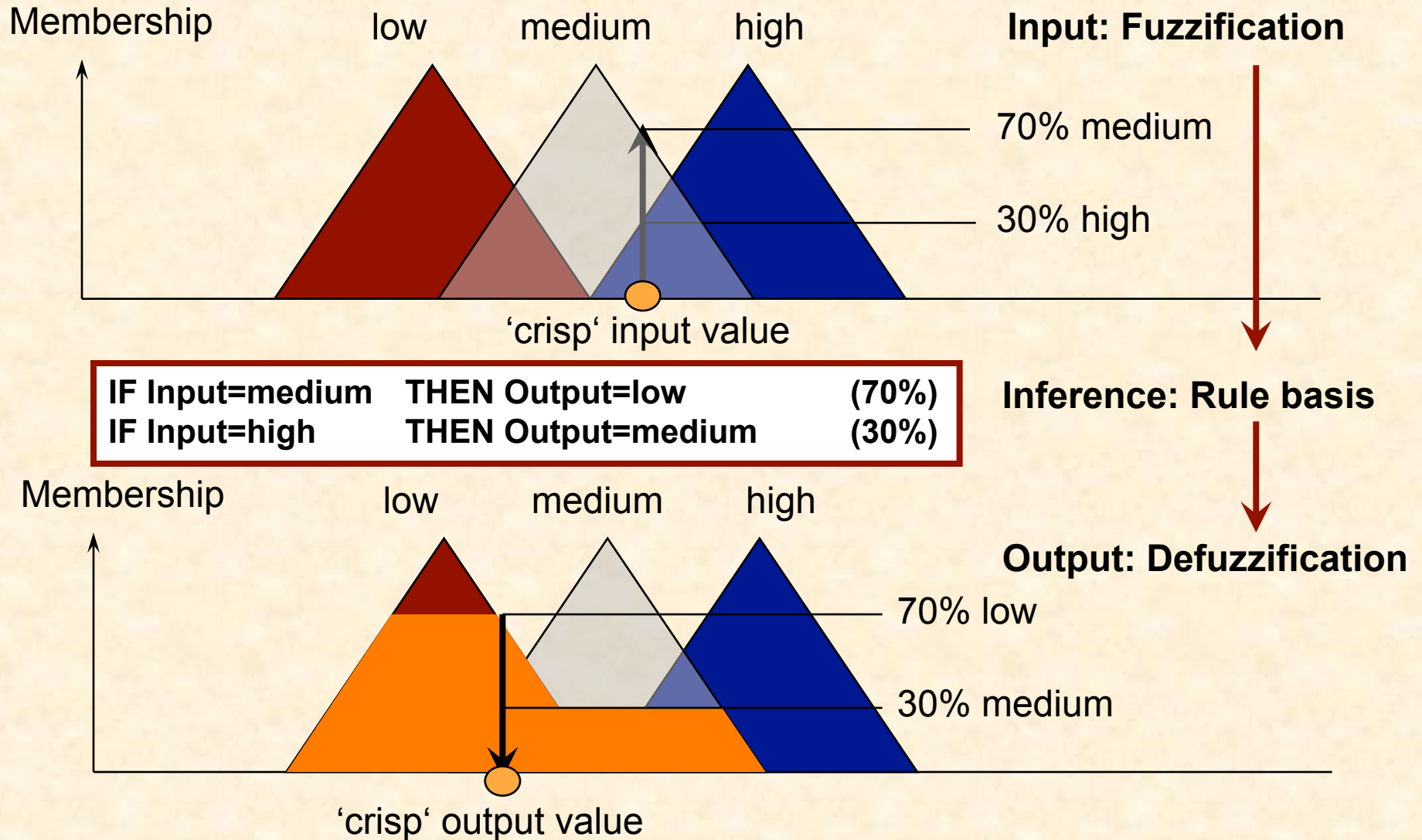

Definitions: intersection, union, complement set



A and B are Fuzzy sets in X:

Intersection: $A \cap B$

$$\mu_{A \cap B}(x) = \text{MIN}(\mu_A(x), \mu_B(x))$$

Union $A \cup B$

$$\mu_{A \cup B}(x) = \text{MAX}(\mu_A(x), \mu_B(x))$$

Complement: F^c

$$\mu_{F^c}(x) = 1 - \mu_F(x)$$

Unit, intersection of fuzzy sets

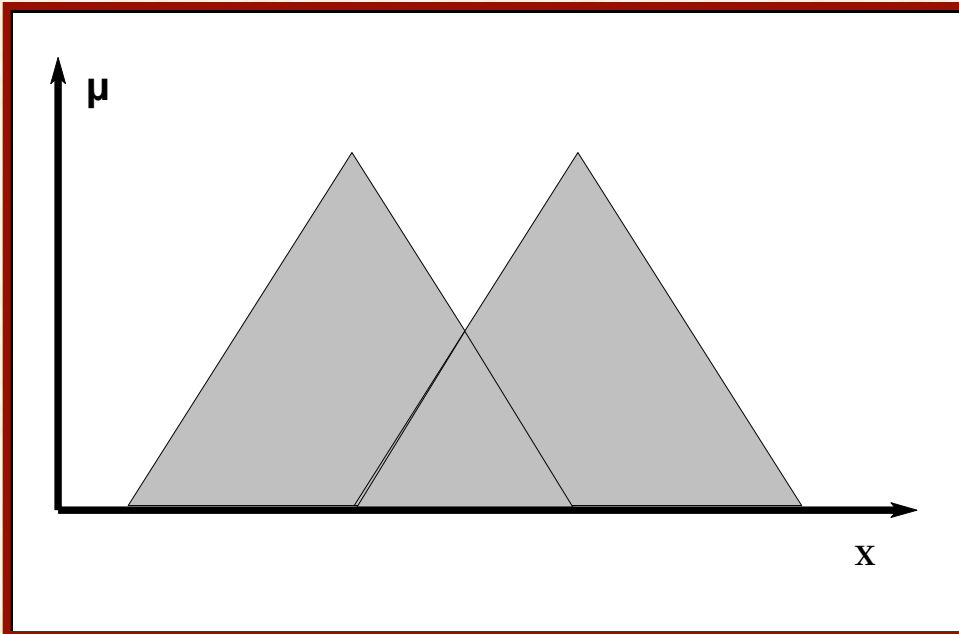

Unit

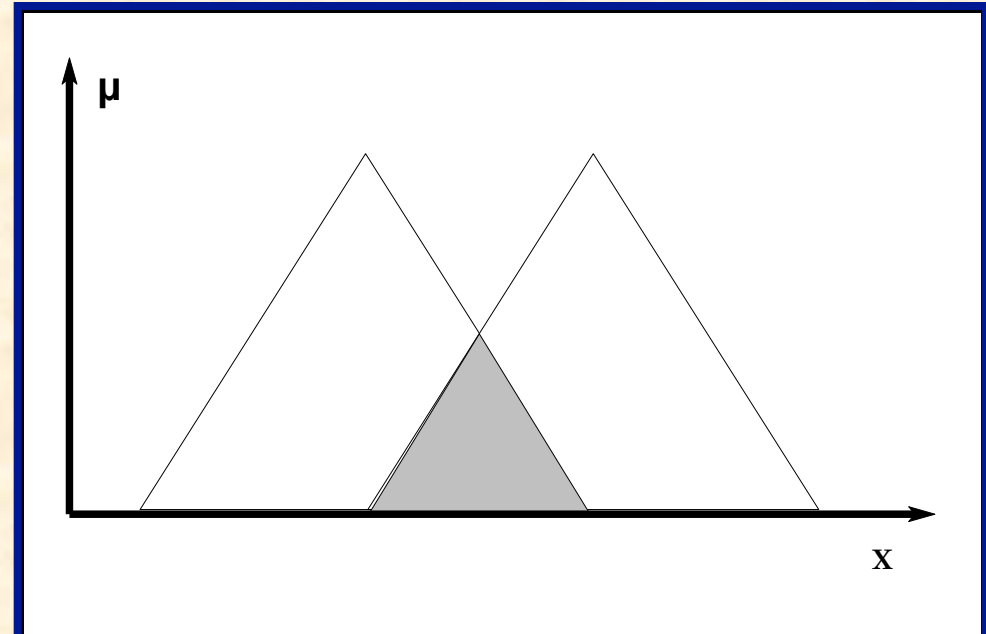

Intersection

Example: Union

- Fuzzy union (\cup): the union of two fuzzy sets is the maximum (MAX) of each element from two sets.
- E.g.
 - $A = \{1.0, 0.20, 0.75\}$
 - $B = \{0.2, 0.45, 0.50\}$

 - $A \cup B = \{\text{MAX}(1.0, 0.2), \text{MAX}(0.20, 0.45), \text{MAX}(0.75, 0.50)\}$

 $= \{1.0, 0.45, 0.75\}$

Example: Intersection

- Fuzzy intersection (\cap): the intersection of two fuzzy sets is just the MIN of each element from the two sets.
- E.g.
 - $A = \{1.0, 0.20, 0.75\}$
 - $B = \{0.2, 0.45, 0.50\}$
 - $A \cap B = \{\text{MIN}(1.0, 0.2), \text{MIN}(0.20, 0.45), \text{MIN}(0.75, 0.50)\}$
 $= \{0.2, 0.20, 0.50\}$

Example: Complement

- The complement of a fuzzy variable with COM x is $(1-x)$.
- Complement ($\bar{\cdot}^c$): The complement of a fuzzy set is composed of all elements' complement.
- E.g.
 - $A = \{1.0, 0.20, 0.75\}$
- $A^c = \{1 - 1.0, 1 - 0.2, 1 - 0.75\}$
 $= \{0.0, 0.8, 0.25\}$

Fuzzy Operations

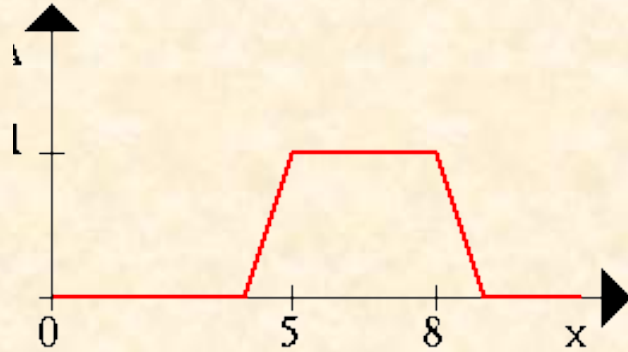

A

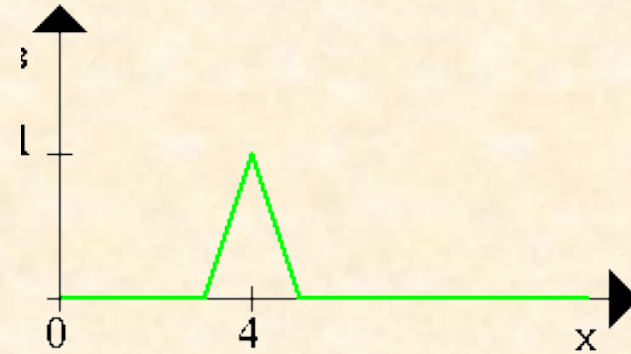

B



$A \wedge B$



$A \vee B$

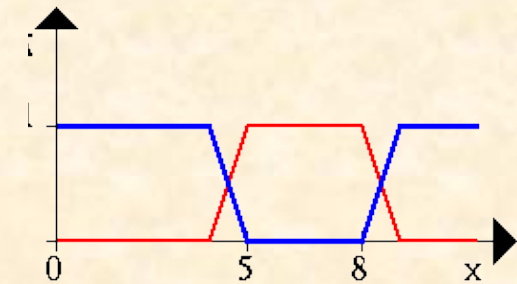

$\neg A$

Definitions: union, intersection, complement set



Union, intersection, complement set
are

**commutative,
associative,
distributive,
de Morgan's law**

Definition of fuzzy set union and fuzzy intersection
two important additional properties:

T (triarangular) and **T-CO-norm**

Definition: T Norm

T is a commutative, associative and two digit map of

$$T: [0,1] \times [0,1] \rightarrow [0,1]$$

T:

$$T - Norm \Leftrightarrow \forall a, b, c, d \in X :$$

$$1. T(0,0) = 0, T(a,1) = T(1,a) = a$$

$$2. T(a,b) \leq T(c,d), \text{ if } a \leq c \text{ and } b \leq d.$$

→ MIN operator

Definition: T-CO Norm

T^* is two digit map of $T^*: [0,1] \times [0,1] \rightarrow [0,1]$

T^* :

T - CO - Norm : $\Leftrightarrow \forall a, b, c, d \in X :$

$$1. T^*(1,1) = 1, T^*(a,0) = T^*(0,a) = a$$

$$2. T^*(a,b) \leq T^*(c,d) \text{ if } a \leq c \text{ and } b \leq d.$$

→ MAX operator

Definition: Linguistic Value (label, predicate)

Linguistic value (label, predicate)

characterizes the quantitative property of a linguistic (signal) variable.

Number of fuzzy sets, Membership functions

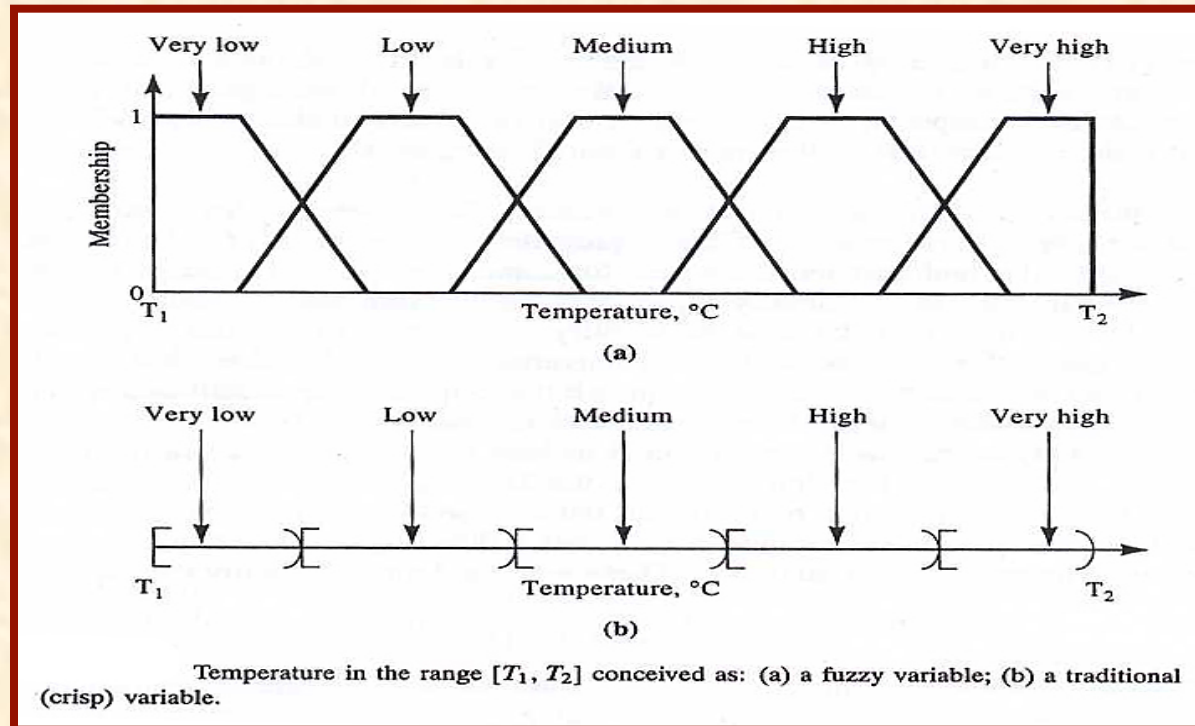

Fuzzy

,traditional'

Definition: Fuzzy Rule, Implication

T is a T-Norm; $A, B \in [0, 1]$; $x, y \in X$ are linguistic variables, whereas x is assigned to A and y to B .

Relation:

IF $x = A$ THEN $y = B \rightarrow$ fuzzy rule

The conclusion applying a fuzzy rule is called

Implication: $A \Rightarrow B$

Examples for Implications

Maximum of Minimum-Implication
(MAX-MIN)

Maximum of Product-Implication
(MAX-PROD)
(MAX-DOT)

Max-Min-/Max-Prod-Implications

Given: fuzzy rules

$$R_1(x.y) = \{[(x, y); \mu_1(x, y)] | (x, y) \in X \times Y\}$$

$$R_2(y.z) = \{[(y, z); \mu_2(y, z)] | (y, z) \in Y \times Z\}$$

Max-Min: $R_{12}(x, z) = R_1(x, y) \circ_{MM} R_2(y, z)$

$$R_{12}(x.z) \equiv \{[(x, z); \max_y \min[\mu_1(x, y), \mu_2(y, z)]] | (x, y, z) \in X \times Y \times Z\}$$

Max-Prod:

$$R_1 \circ_{MP} R_2 = \{[(x, z); \max_y (\mu_{R_1}(x, y) \cdot \mu_{R_2}(y, z))] | (x, y, z) \in X \times Y \times Z\}$$

Max-Min-/Max-Prod-Implications



IF

THEN

max-dot

max-min

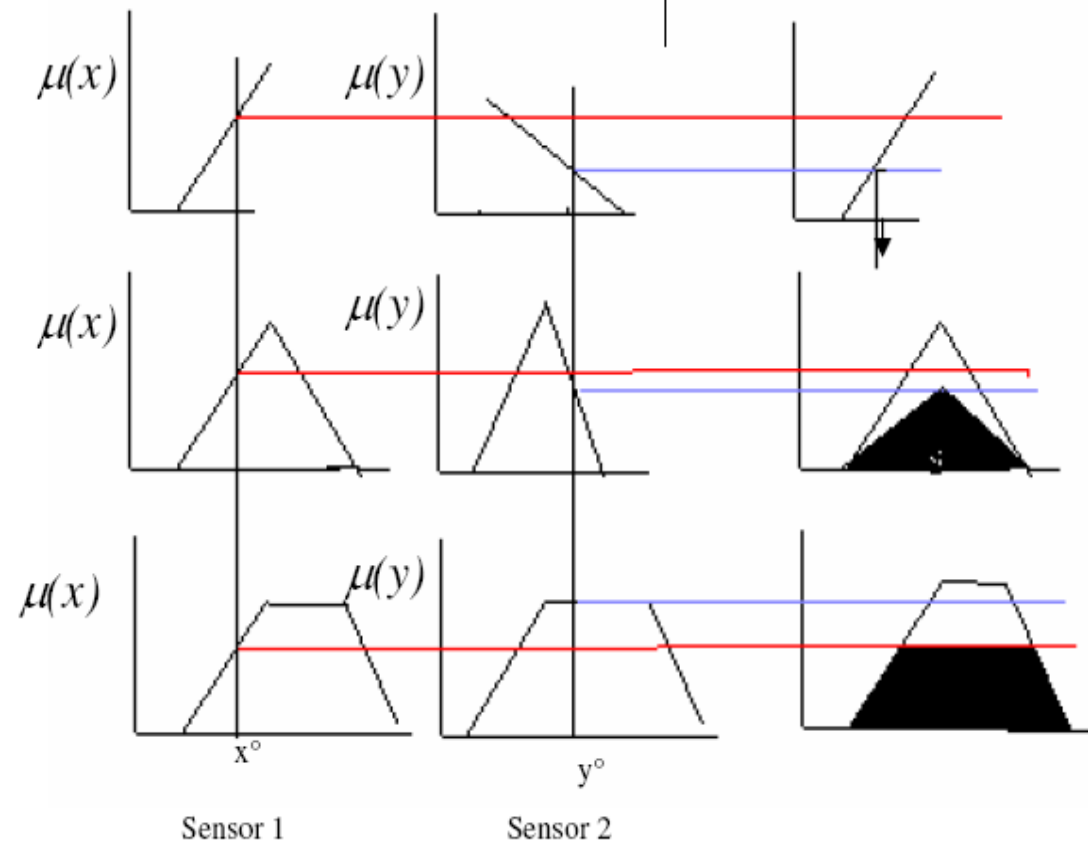

The lower value is selected assuming that the conjunctive AND is implemented as intersection

Types of defuzzification

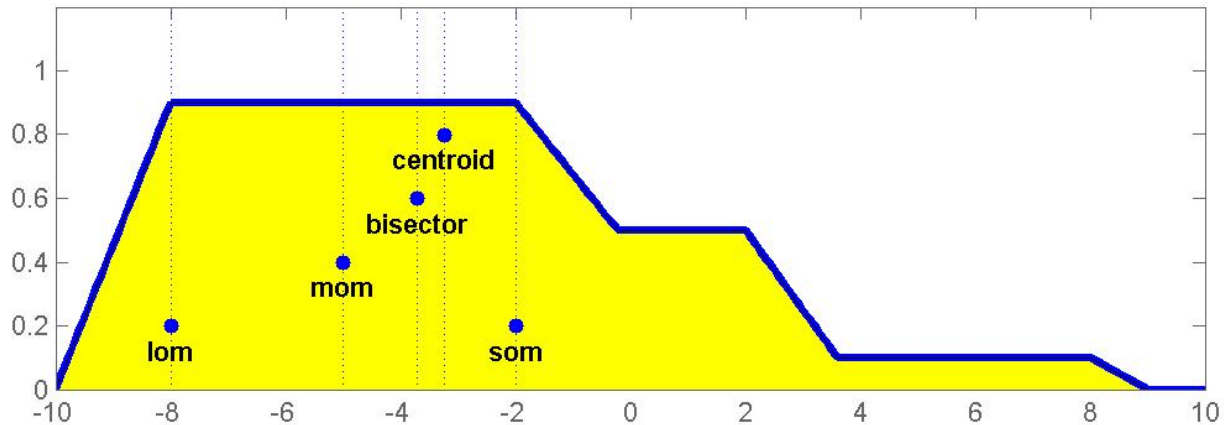

Lom: last-of-maximum
Mom: middle-of-maximum
Som: smallest-of-maximum
Centroid: centroid-of-area
Bisector: bisector-of-area

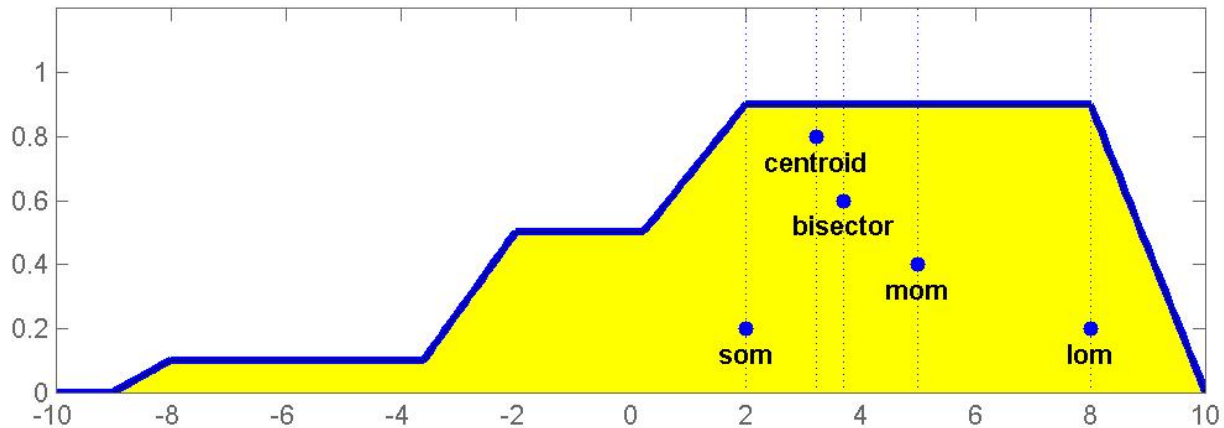

Definition: Defuzzification

F is a fuzzy set in X: The map $DE : X \rightarrow tr(F)$ is called **defuzzification** under one of the following conditions:

1. $y_{area} = DE(F) = \frac{\int \mu_F(x) x dx}{\int \mu_F(x) dx}$
2. $y_{max} = DE(F) = x_0$ with $\mu_F(x) \leq \mu_F(x_0) \forall x \in X$
3. $y_{mmax} = DE(F) = \frac{\sum_{x \in W} x}{|W|}$ with $W = \{x | \mu_F \text{ is Maximum}\}$

3. Fuzzy design

Components of a fuzzy systems



- Set of linguistic input- and output variables,
- Set of fuzzy „if... then... “-rules
- T-Norm, assignment of the input fuzzy sets to the fuzzy rules
- Implication
- T-CO-Norm, assignment of the fuzzy rules to the output fuzzy sets
- Method of defuzzification

Fuzzy Relations Matrices

- Example: Color-Ripeness relation for tomatoes

$R_1(x, y)$	unripe	semi ripe	ripe
green	1	0.5	0
yellow	0.3	1	0.4
Red	0	0.2	1



Fuzzification

- Two Inputs (x, y) and one output (z)
- Membership functions:

$$- \text{low}(t) = 1 - (t / 10)$$

$$- \text{high}(t) = t / 10$$

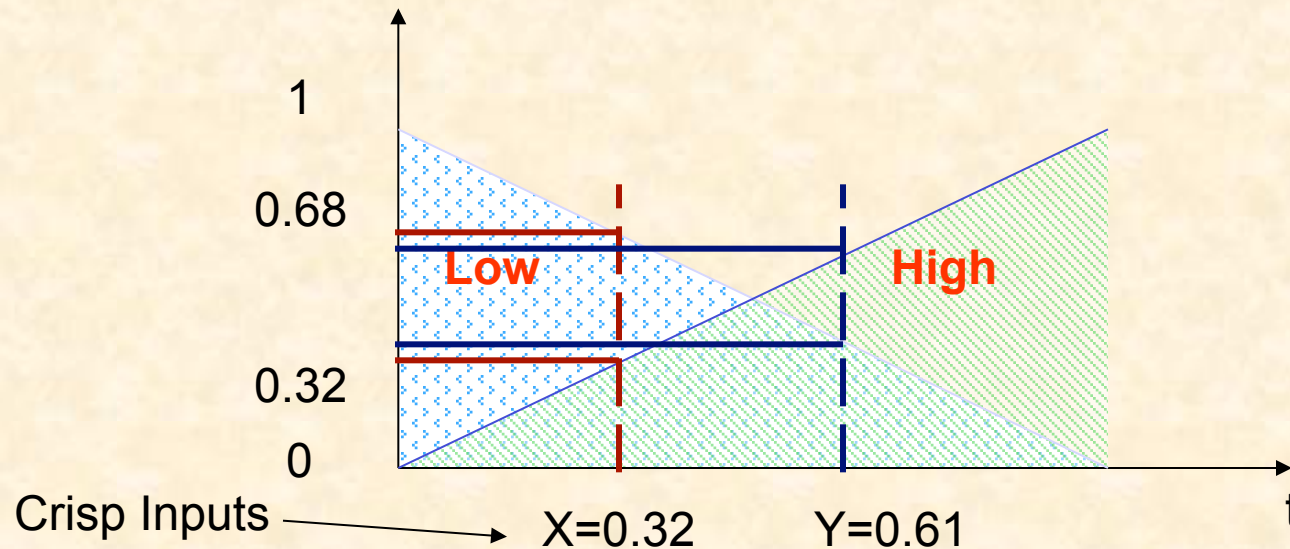

$$\text{Low}(x) = 0.68, \quad \text{High}(x) = 0.32, \quad \text{Low}(y) = 0.39, \quad \text{High}(y) = 0.61$$

Create rule base



- Rule 1: If x is low AND y is low THEN z is high
- Rule 2: If x is low AND y is high THEN z is low
- Rule 3: If x is high AND y is low THEN z is low
- Rule 4: If x is high AND y is high THEN z is high

Inference (MAX-MIN)

- Rule1: $\text{low}(x)=0.68, \text{low}(y)=0.39 \Rightarrow$
 $\text{high}(z)=\text{MIN}(0.68,0.39)=0.39$ Rule strength
- Rule2: $\text{low}(x)=0.68, \text{high}(y)=0.61 \Rightarrow$
 $\text{low}(z)=\text{MIN}(0.68,0.61)=0.61$
- Rule3: $\text{high}(x)=0.32, \text{low}(y)=0.39 \Rightarrow$
 $\text{low}(z)=\text{MIN}(0.32,0.39)=0.32$

- Rule 1: If x is low AND y is low THEN z is high
- Rule 2: If x is low AND y is high THEN z is low
- Rule 3: If x is high AND y is low THEN z is low
- Rule 4: If x is high AND y is high THEN z is high

Composition

• $\text{Low}(z) = \text{MAX}(\text{rule2}, \text{rule3}) = \text{MAX}(0.61, 0.32) = 0.61$

• $\text{High}(z) = \text{MAX}(\text{rule1}, \text{rule4}) = \text{MAX}(0.39, 0.32) = 0.39$

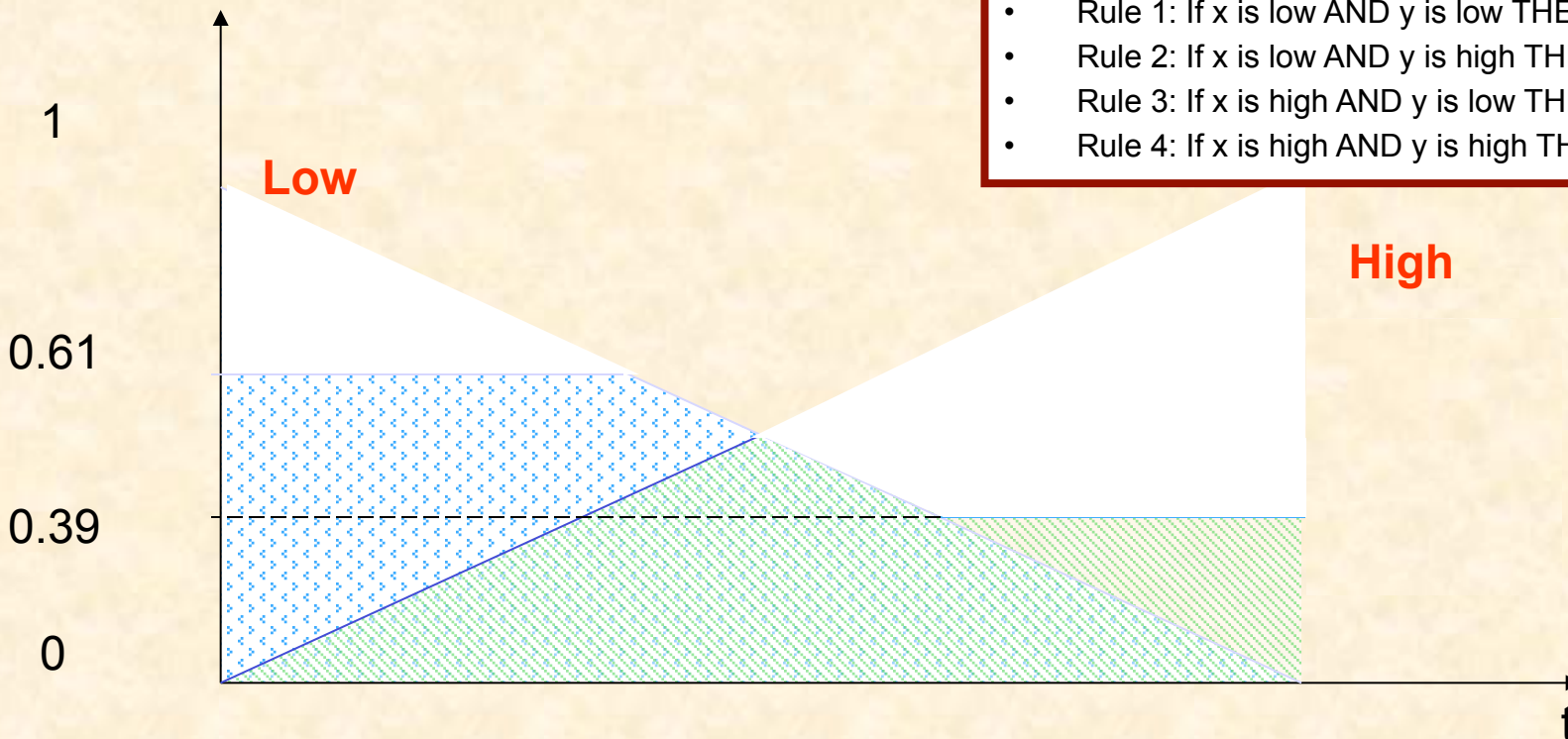

- Rule 1: If x is low AND y is low THEN z is high
- Rule 2: If x is low AND y is high THEN z is low
- Rule 3: If x is high AND y is low THEN z is low
- Rule 4: If x is high AND y is high THEN z is high

Defuzzification

- Center of Gravity

$$C = \frac{\int_{Min}^{Max} tf(t)dt}{\int_{Min}^{Max} f(t)dt}$$

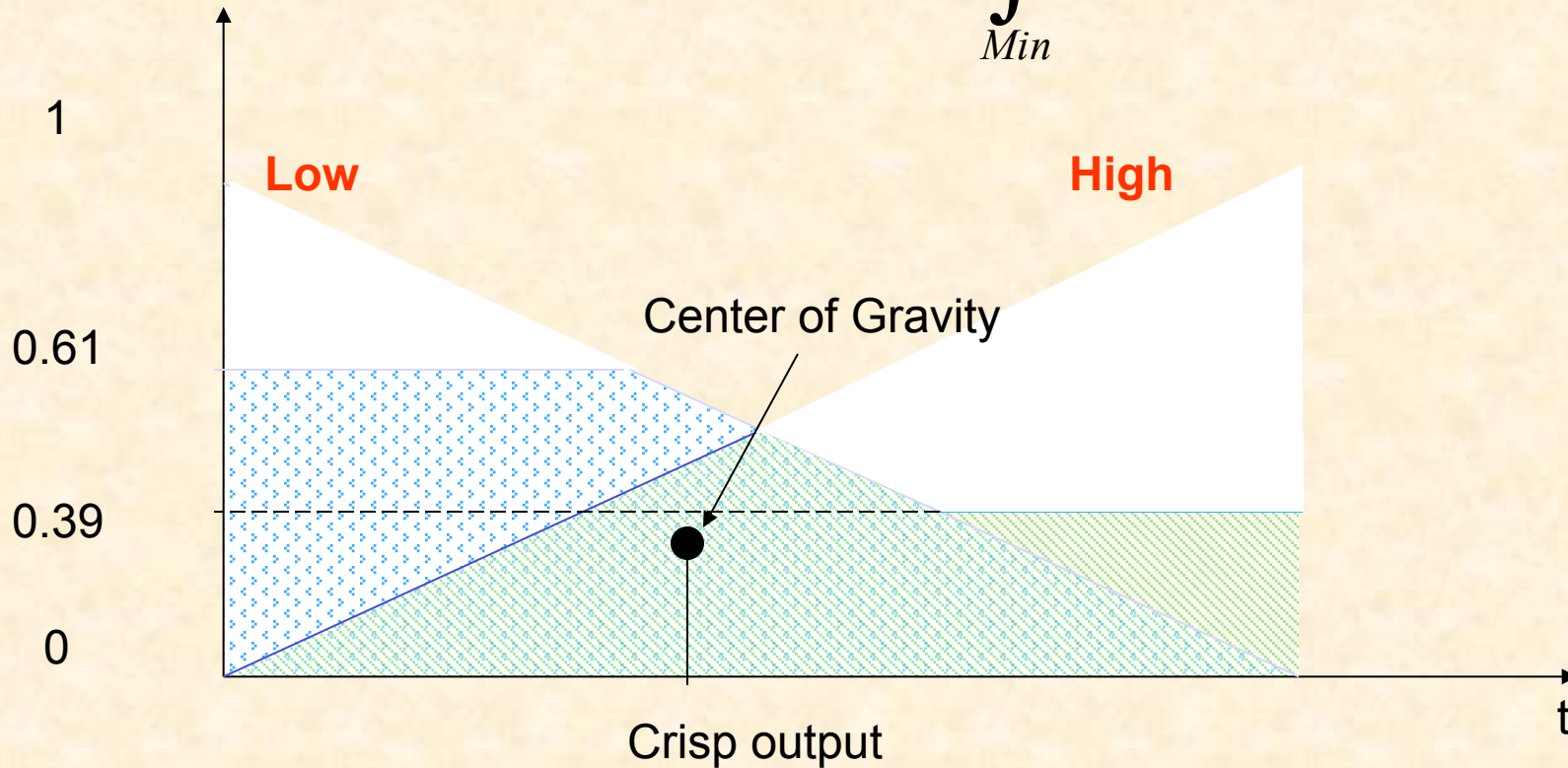

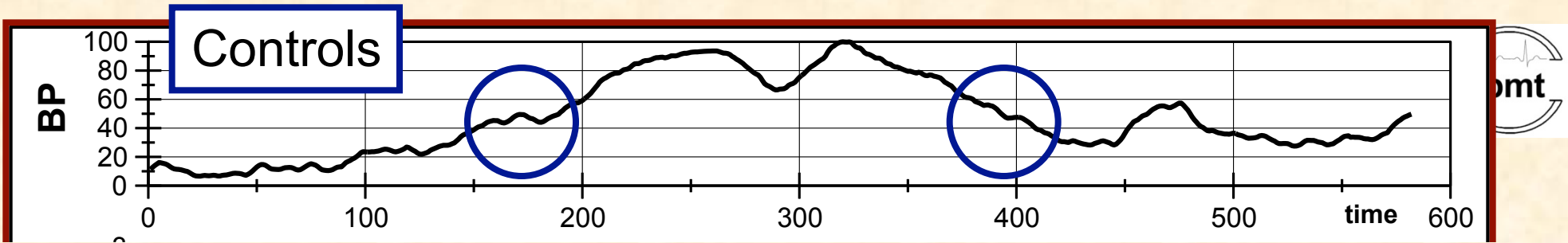

Contradictions!

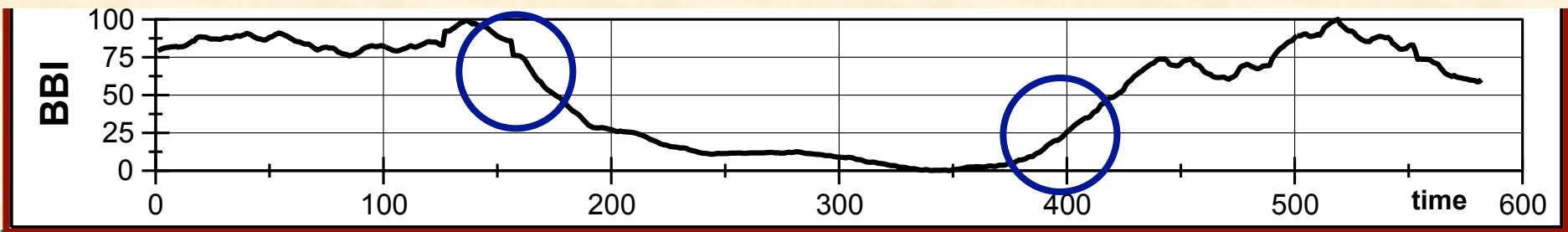

Controls

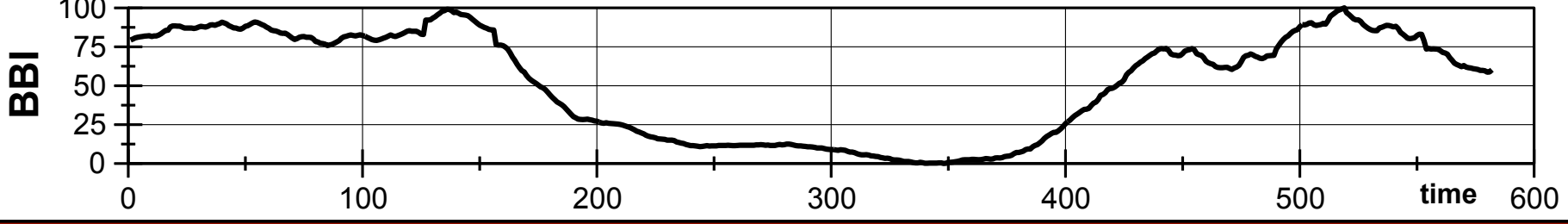
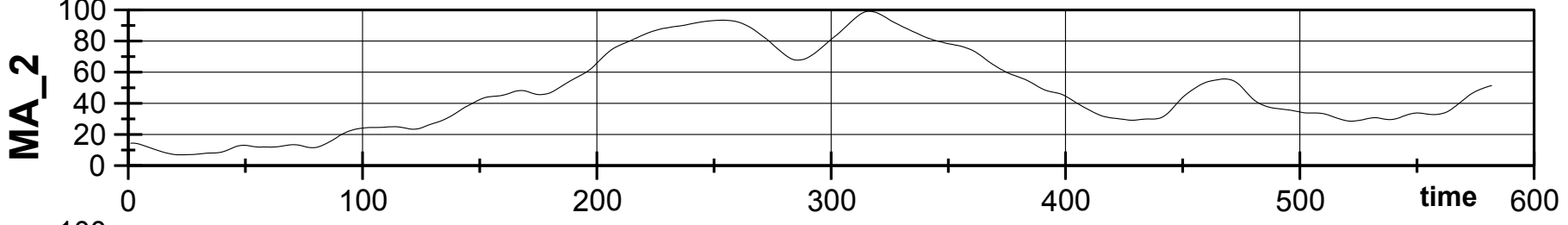
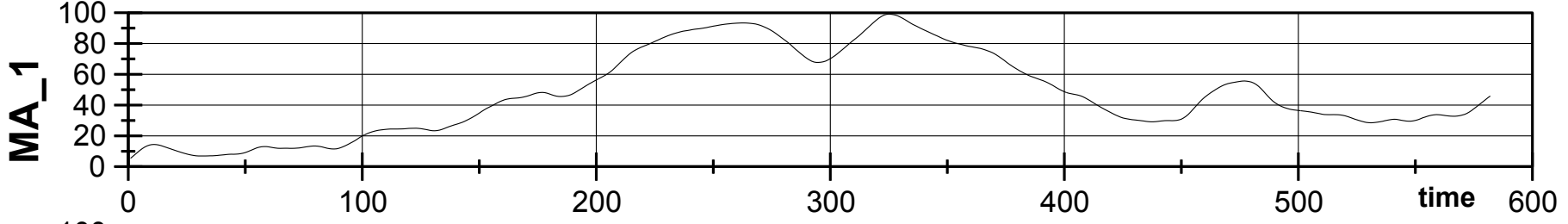
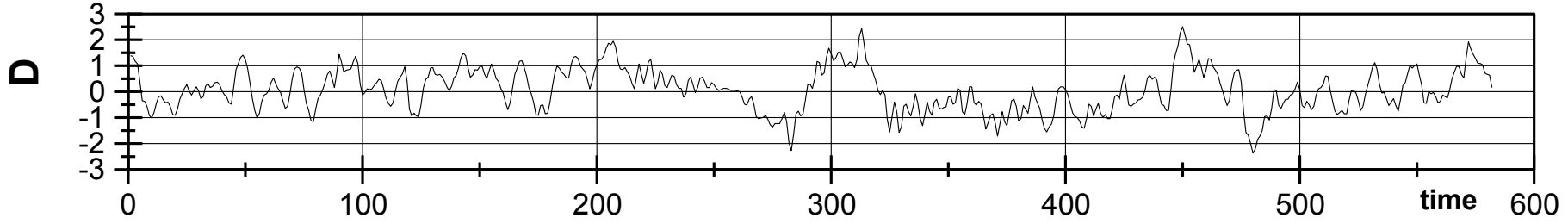
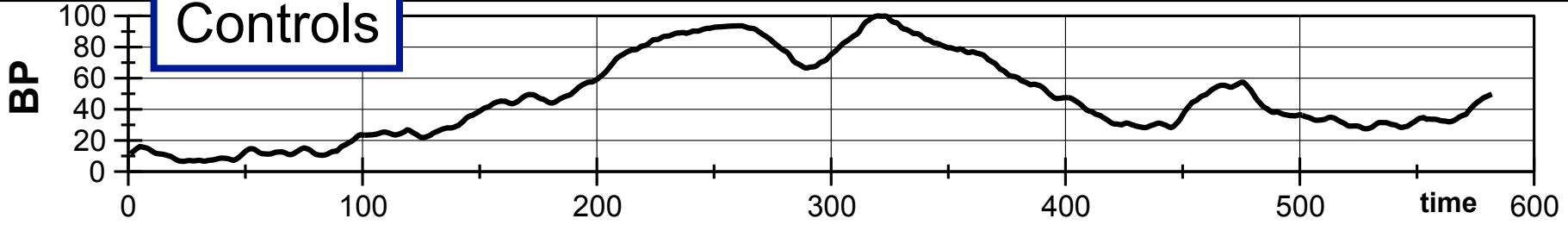

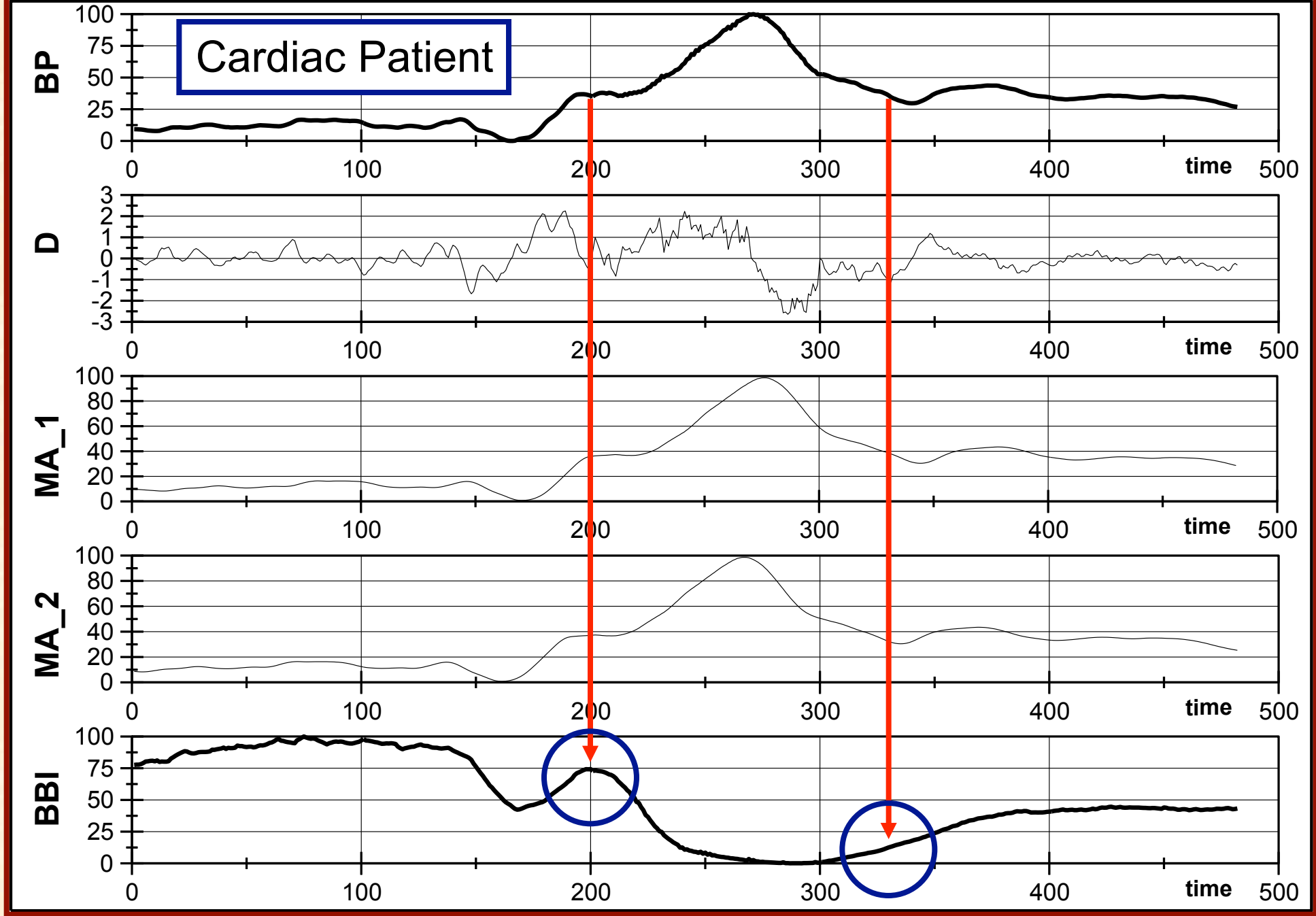

3. Machine Learning Algorithms

Algorithms for Rule Generation of Fuzzy Systems



	Direct access	Indirect access
Heuristic inductive	ASMOD Fuzzy CART LOLIMOT Fuzzy-Decision trees	Fuzzy-Rosa (explorative standard strategy) Tree based Rule generation Fuzzy Version Space Learning Inductive learning on modulare Fuzzy-Rules Induction hierarchic Fuzzy-Systems
Probabilistic	GA-based design of Fuzzy-Systems Neuro-Fuzzy-Systems	Evolutionary Rule Generation Fuzzy-ROSA (evolutionary strategy) GA-based rule generation

Automatic Fuzzy Design

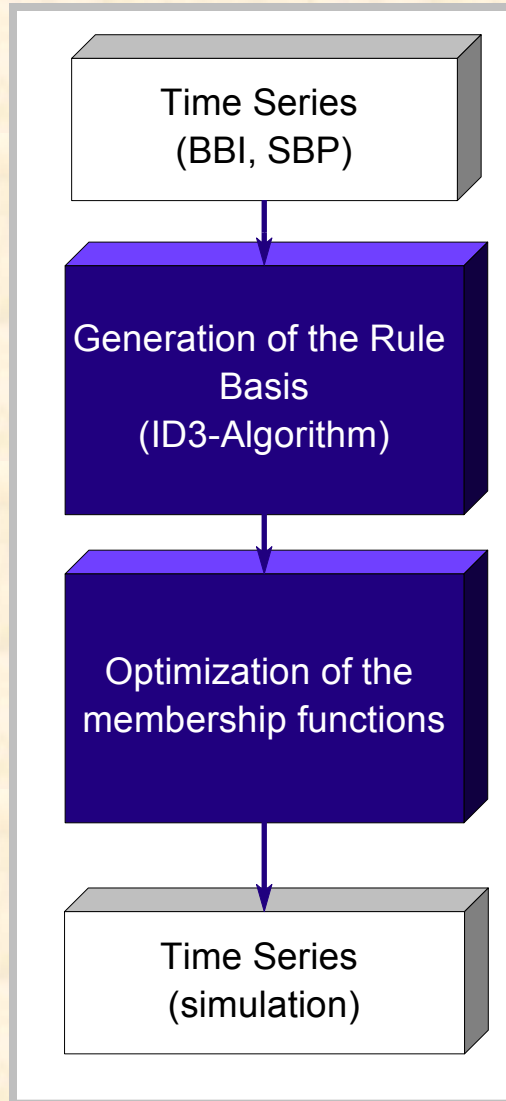

Definitions:

- fix number membership functions (MS-F) per in-/output
- Fuzzification of input signals by segments linear MSF
- Sum of MS values is 1
- MSF of output: Singletons
- method of inference: MAX-MIN
- all rules are weighted with 1

Automatic Fuzzy Design



Fuzzy Control Design Toolbox für MATLAB® FCD V2.0

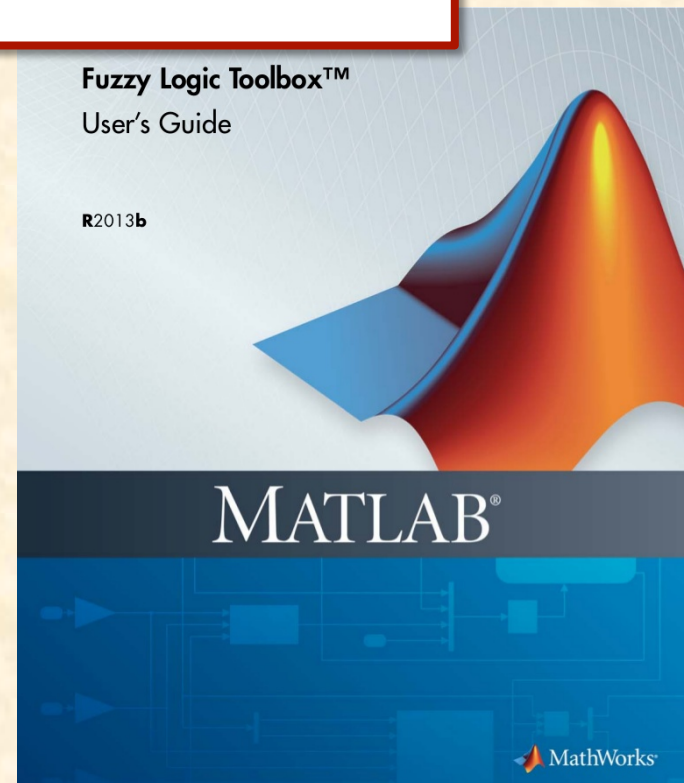

1. Example:

Baroreflex analysis in a transgenic rat model

Baroreceptor Reflex

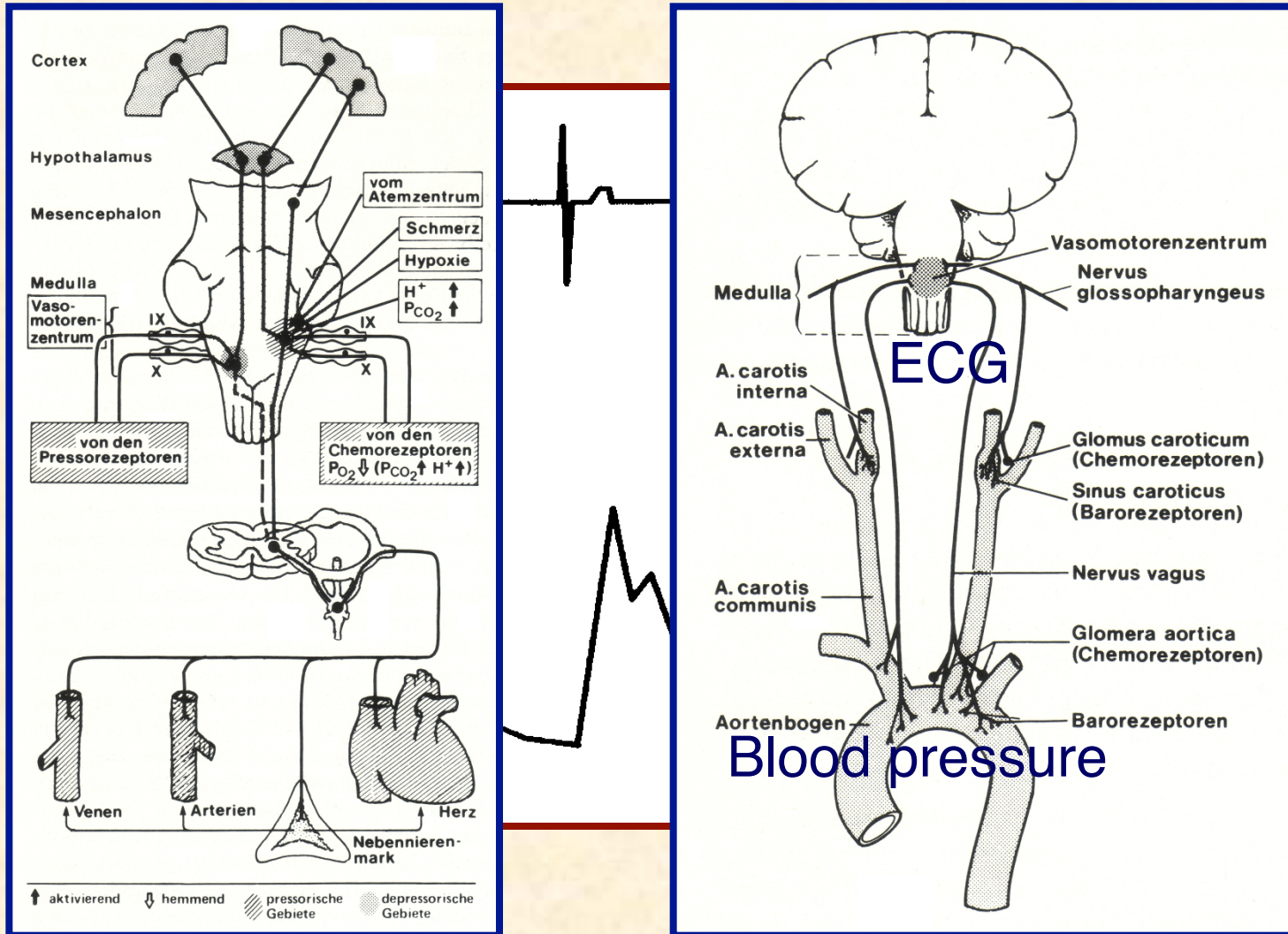

aus Bleifeld:
Springer, 1987

Analysis of the induced baroreceptor sensitivity

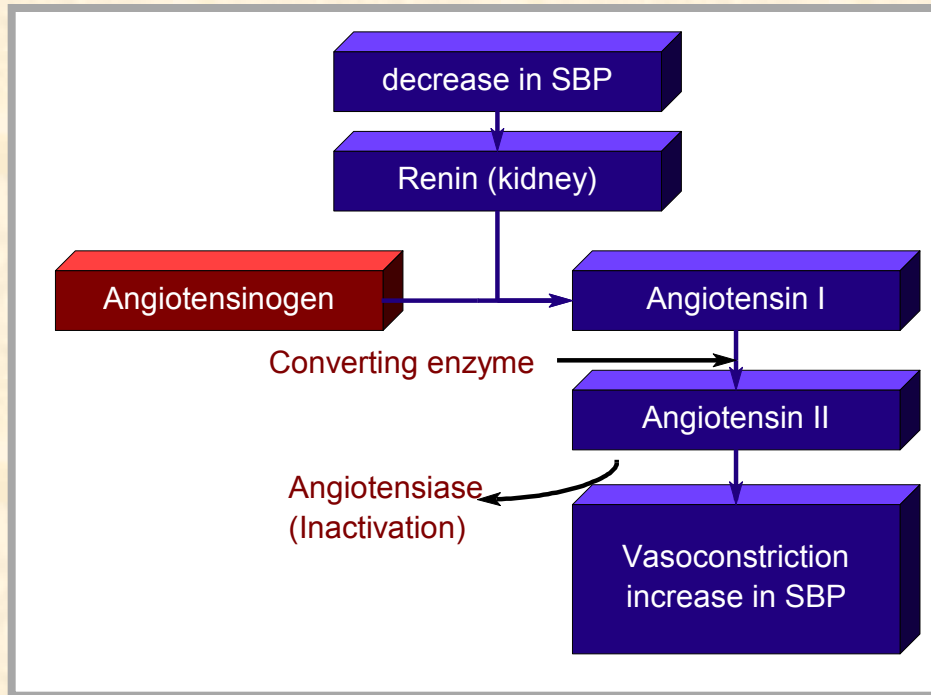

Hypothesis:

Investigation of regulatory differences in BR control in dependence on gender and genetic

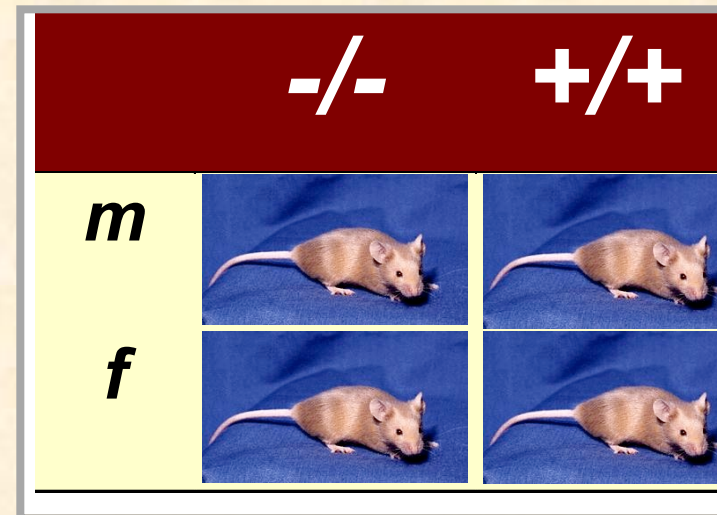

each 6 mice/group

Selected Methods for Estimation the BR



Range	Method	BRS estimation by calculation of
Time domain	Sequence method <i>Mancia 1983, Parati 2000</i>	Regression of increases and decreases in SBP and NNI
Frequency domain	Alpha-Method <i>Bertinieri 1985</i>	Root of ratio of NNI- and SBP-Spectra (LF and HF range)
	Transfer function <i>Robbe 1987</i>	Transfer function of LF and HF range between NNI- and SBP-spectra
Combined time- and frequency domain	Dual Sequence method <i>Malberg 2002</i>	Frequency selected and extended measures from regression
	Complex Demodulation <i>Kim 1997</i>	Relation of amplitudes between SBP and NNI-Oscillations LF-range
Model based analysis	ARMA-Model <i>Patton 1996</i>	Relation between coupling of SBP and NNI (BRS) and back coupling
	Fuzzy-Model <i>Malberg 2002</i>	non-linear relation between SBP and NNI by machine learning and optimized fuzzy system
Statistical analysis	Z-Analysis <i>Ducher 1994, Cerutti 1997</i>	statistical dependance of NNI and SBP

Baroreflex analysis

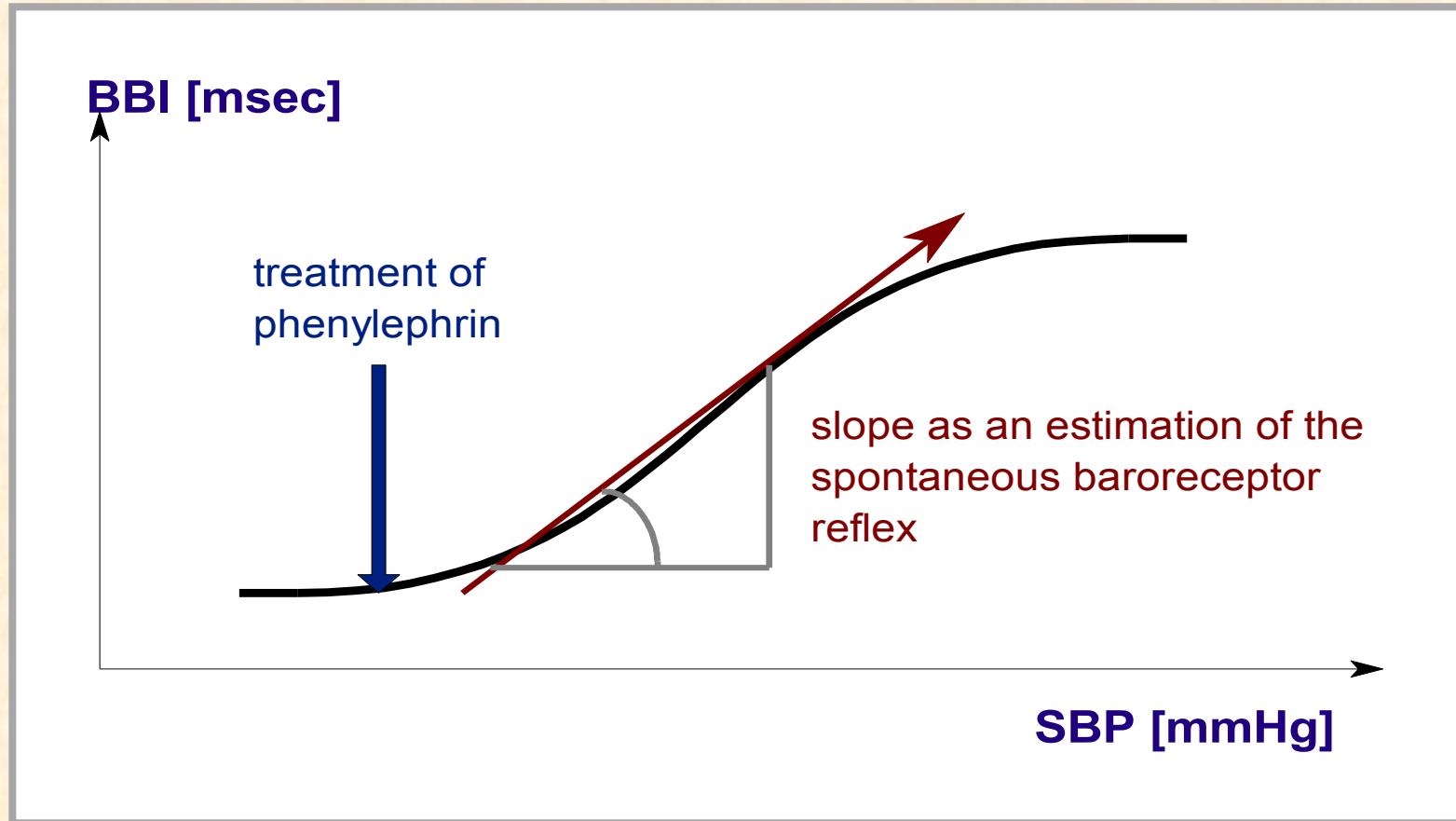

BBI: beat-to-beat interval (inverse heart rate)
SBP: systolic blood pressure

Original time series

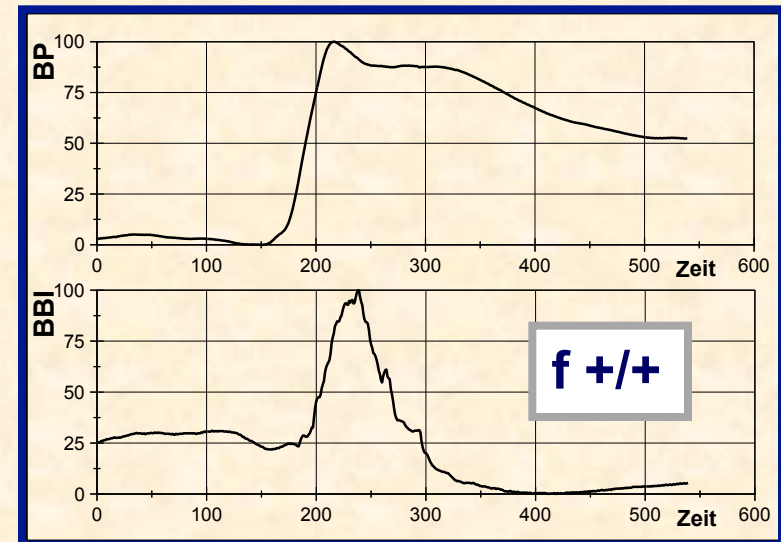
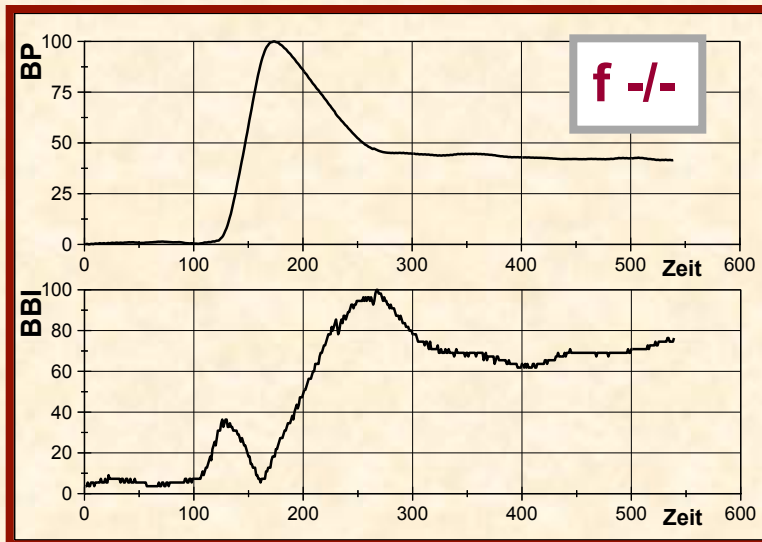
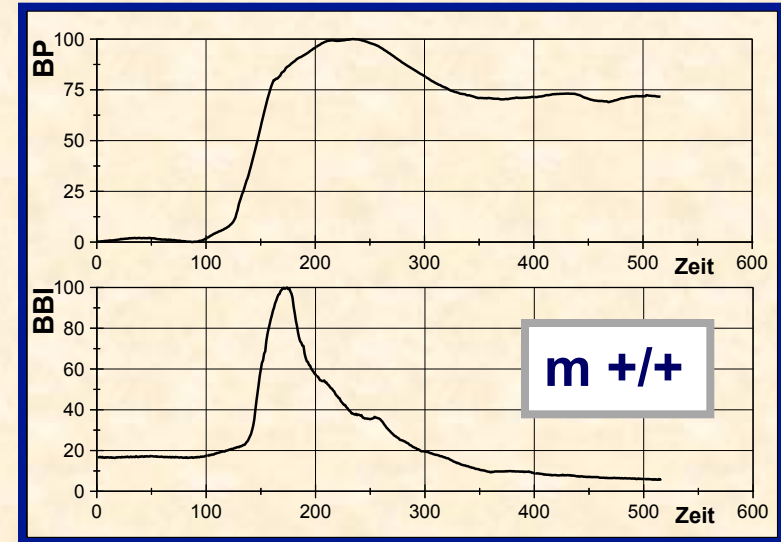
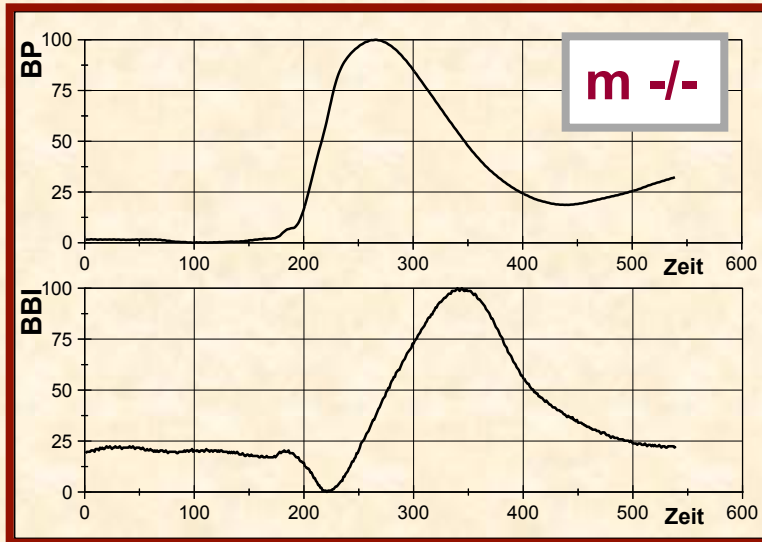

Model structure

Normalization:

$$x^* = \frac{(x - x_{\min}) \cdot 100}{x_{\max} - x_{\min}}$$

D:

$$A_D(z) = \frac{1}{2} (1 - z^{-2})$$

MA_1, MA_2, MA_3:

$$A_I(z) = \frac{1}{N} \sum_{n=0}^{N-1} z^{-n} \text{ with } N = 30,$$

$$\text{MA}_3: N = 10$$

MSF	Code
<i>very small</i>	-2
<i>small</i>	-1
<i>medium</i>	0
<i>big</i>	1
<i>very big</i>	2

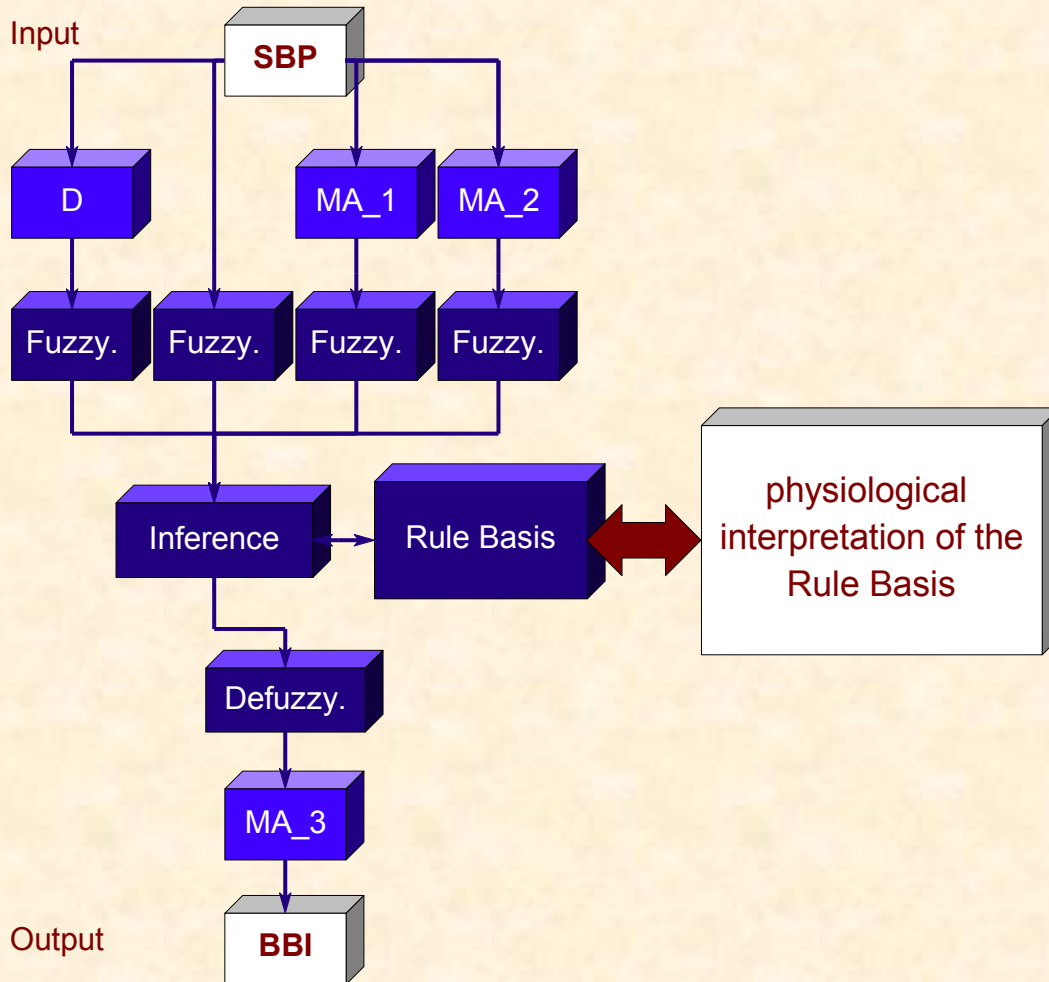

Complete model time series

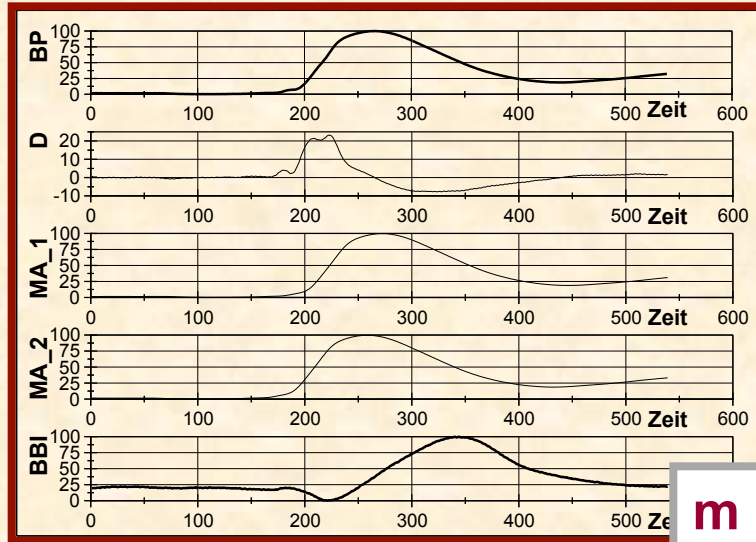

m -/-

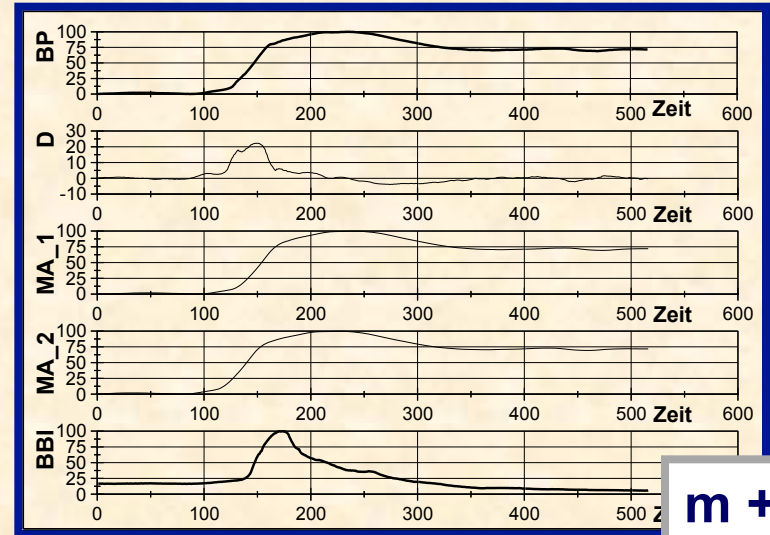

m +/+

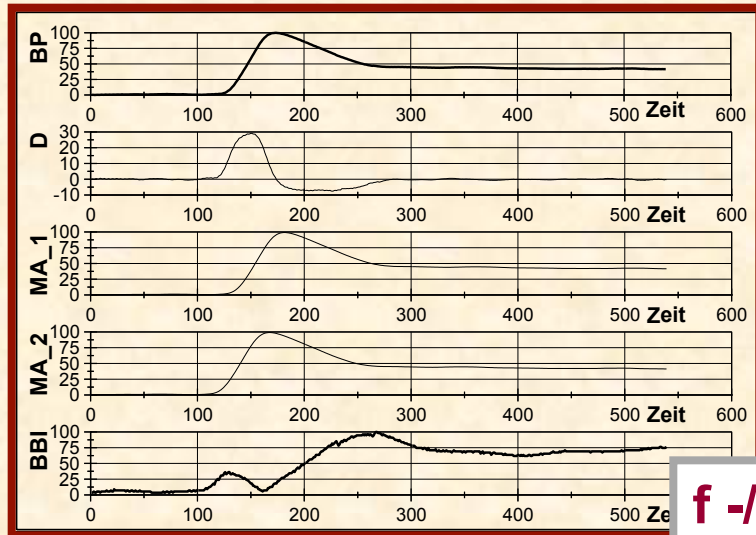

f -/-

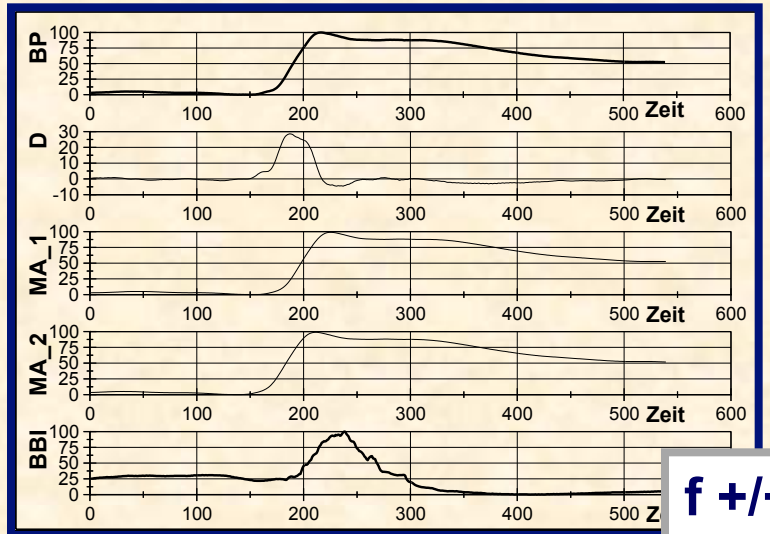

f +/+

Simulated time series

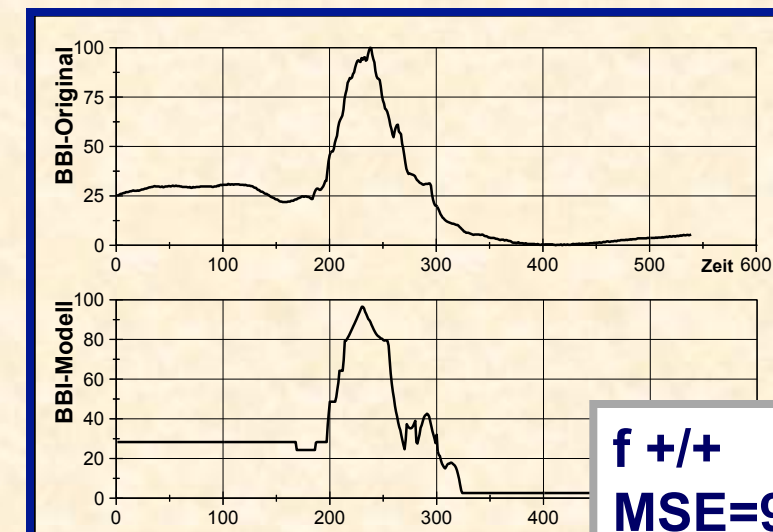
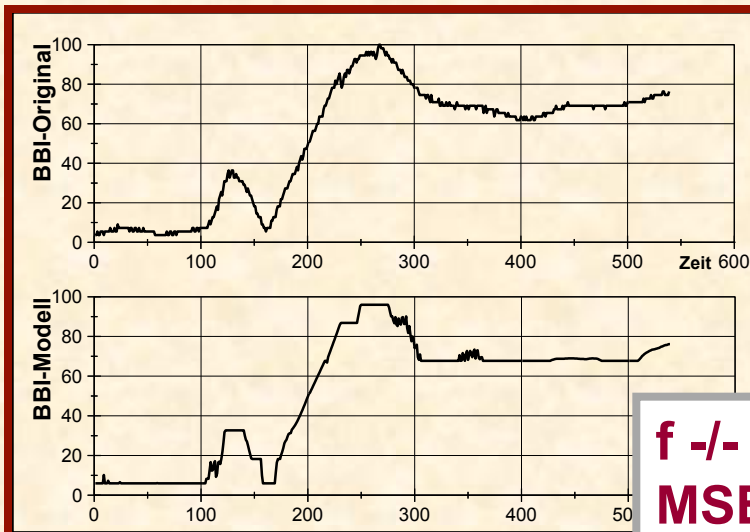
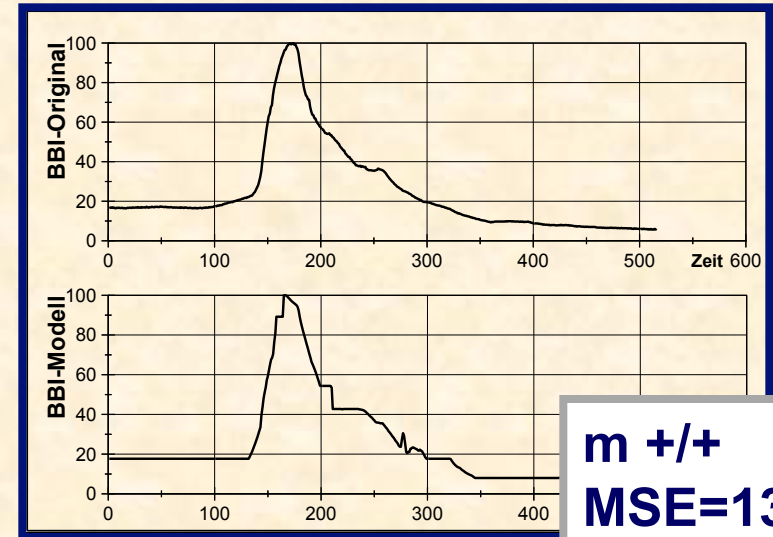
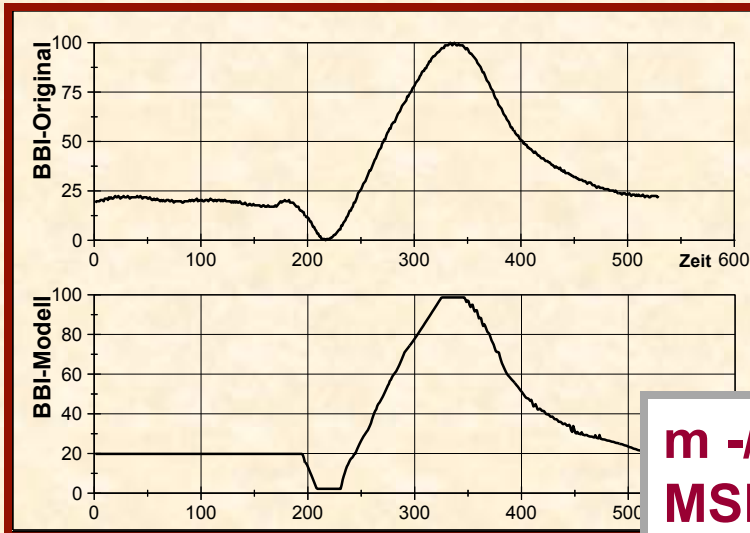

Rule bases of -/--models

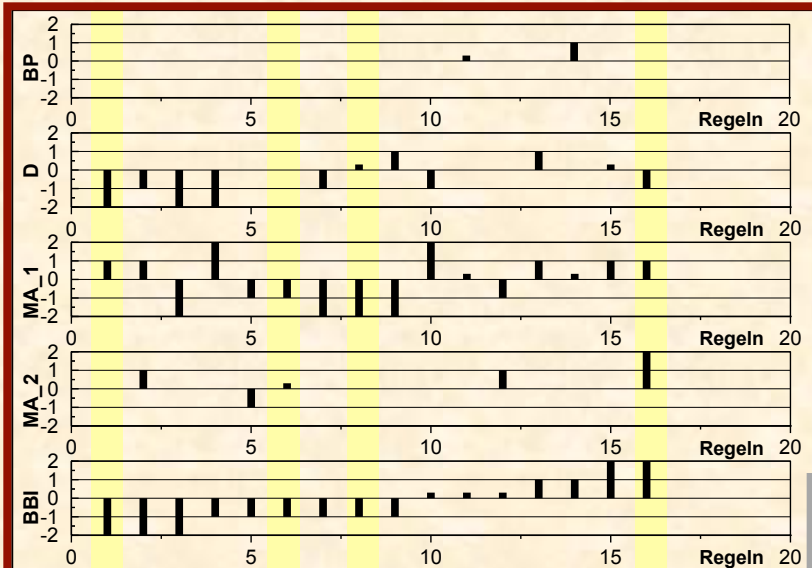

m -/-

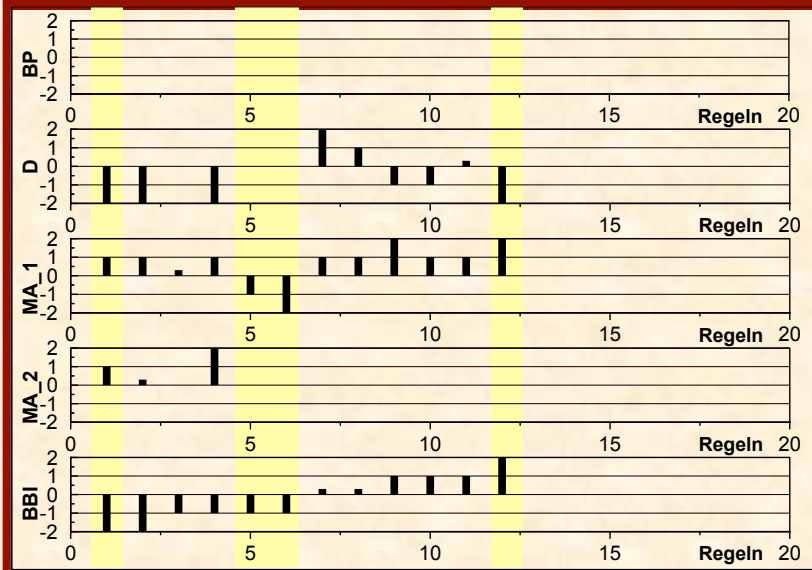
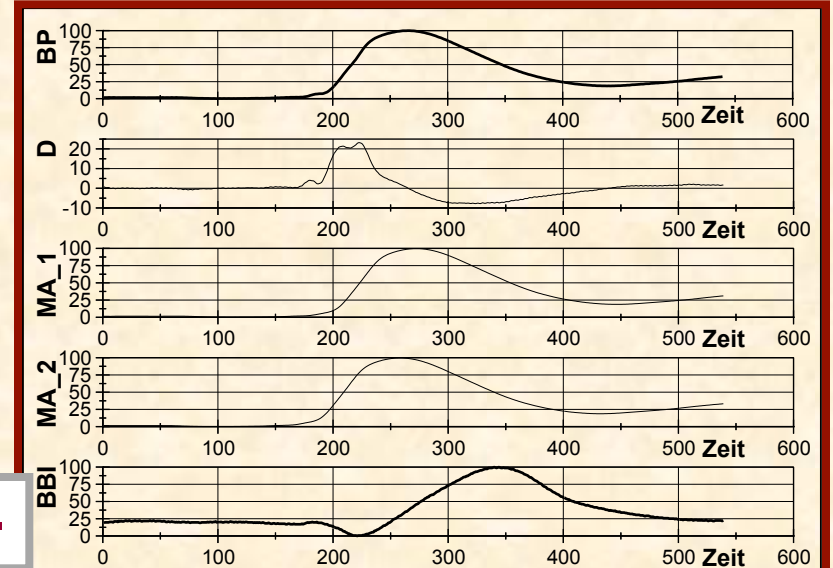

f -/-

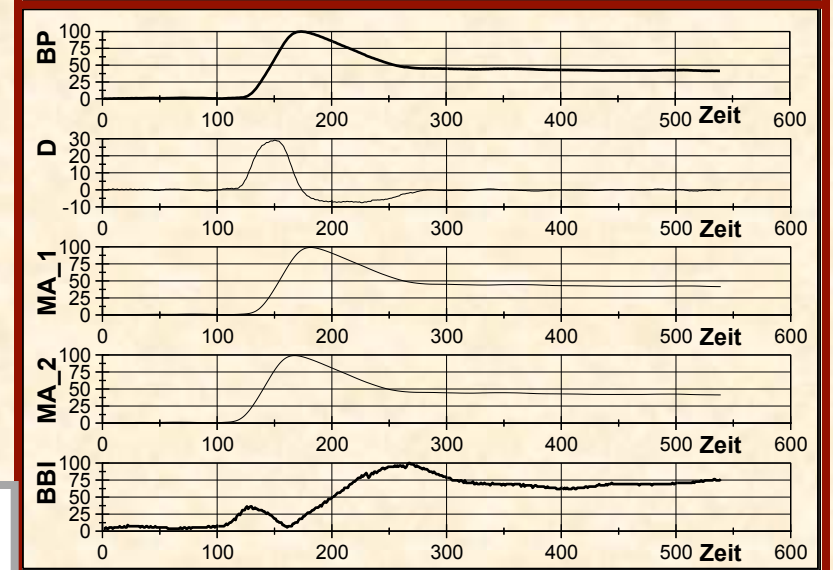

Rule bases of +/--models

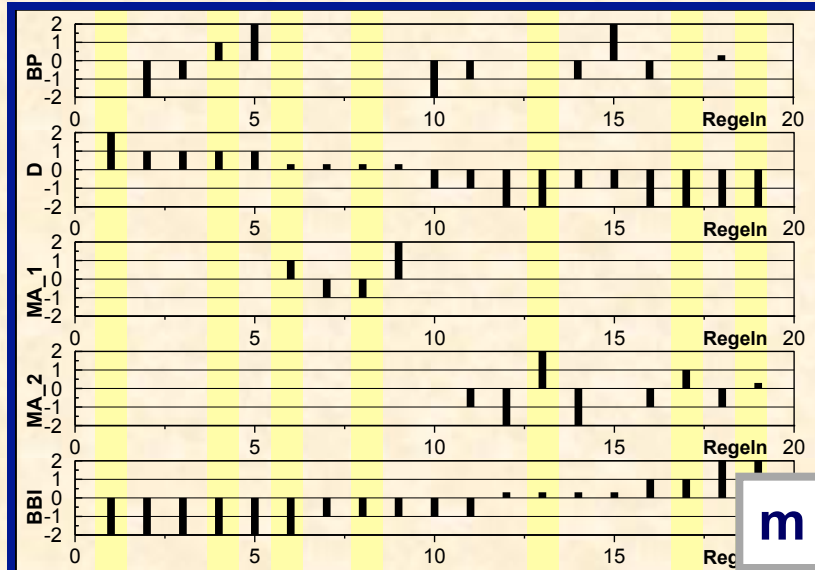

m +/+

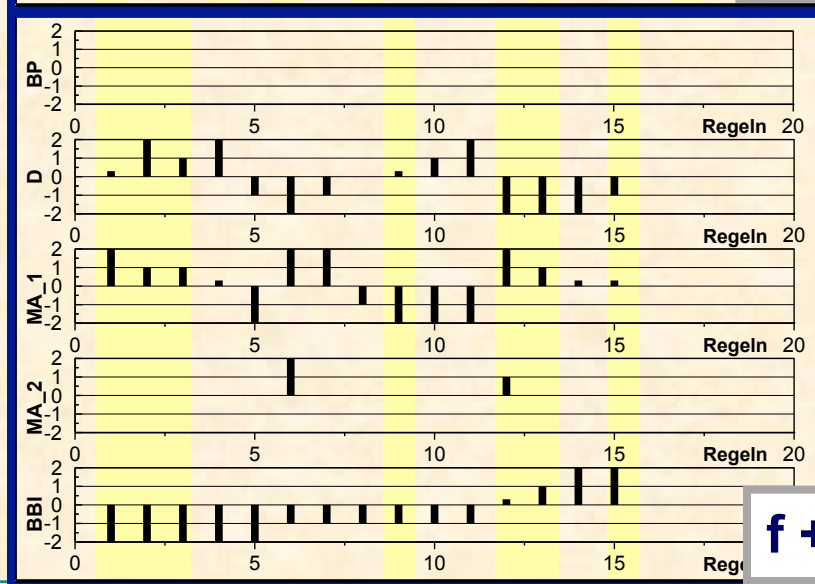
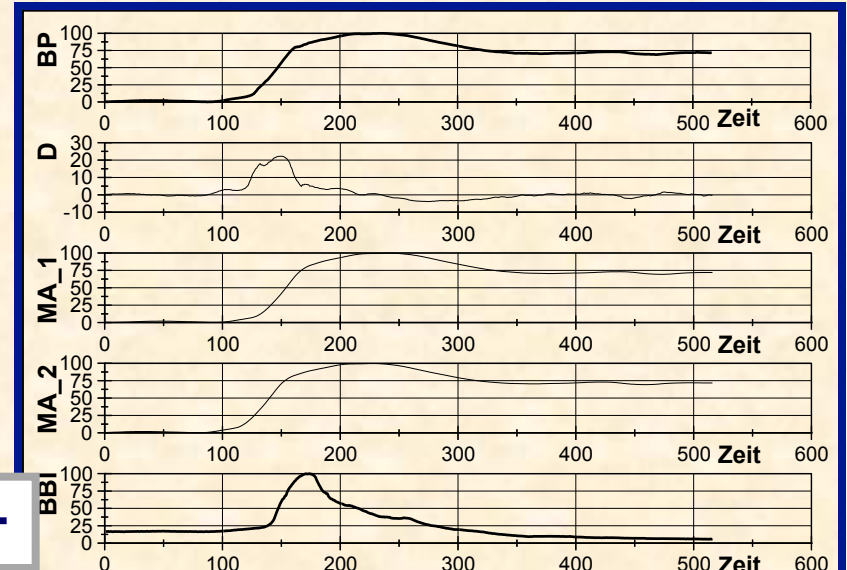

f +/+

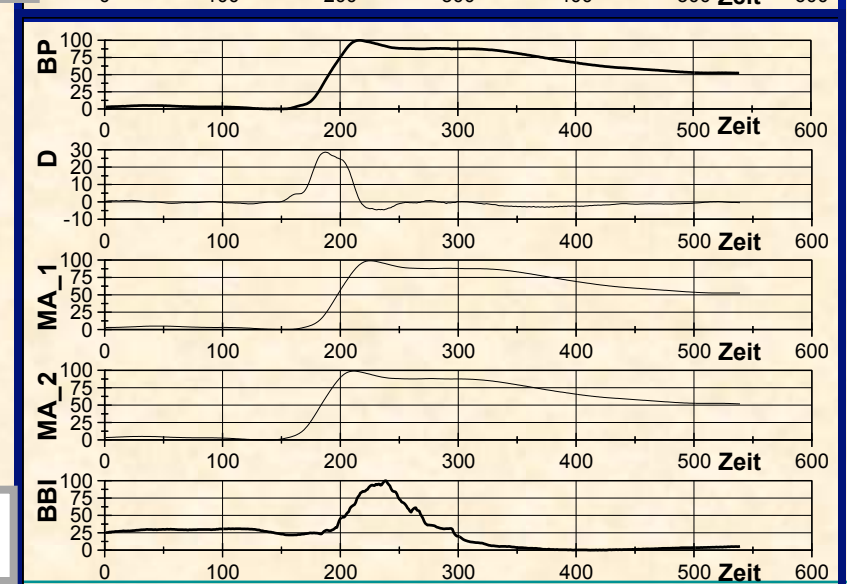

Comparisons

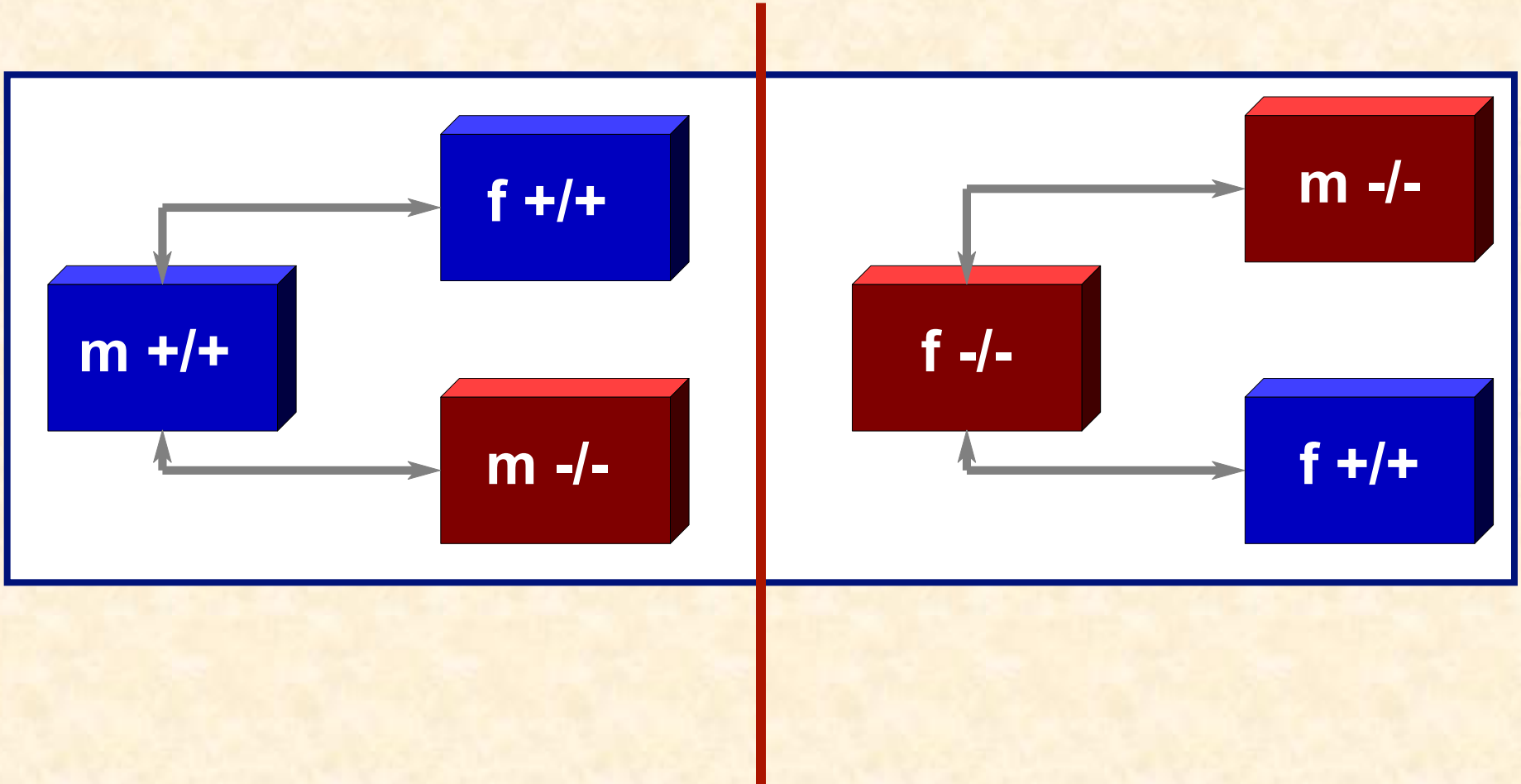

Model specificity:

Gender:

Genetic:

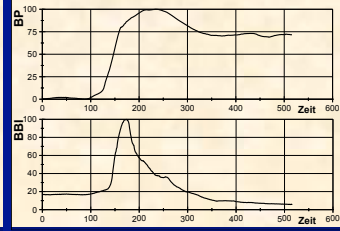

Model +/+ m
(MSE=13.9)

+/- f:

MSE=18.9

-/--m:

MSE=35.8

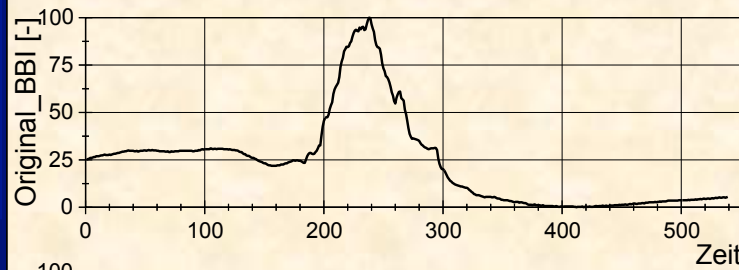

f +/+

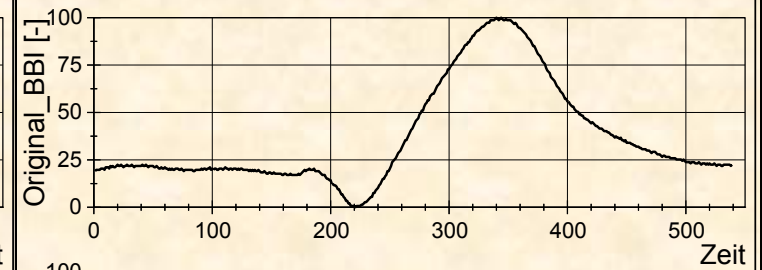

m -/-

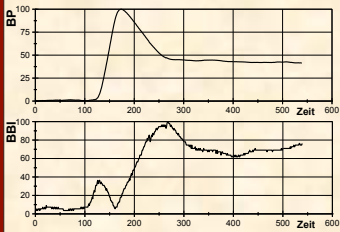

Modell -/- f
(MSE=8.4)

-/--m:

MSE=14.2

+/-f:

MSE=52.9

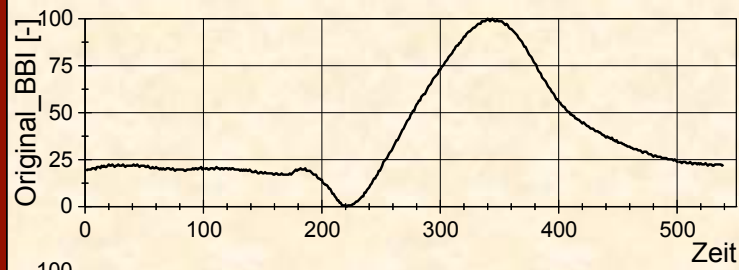

m -/-

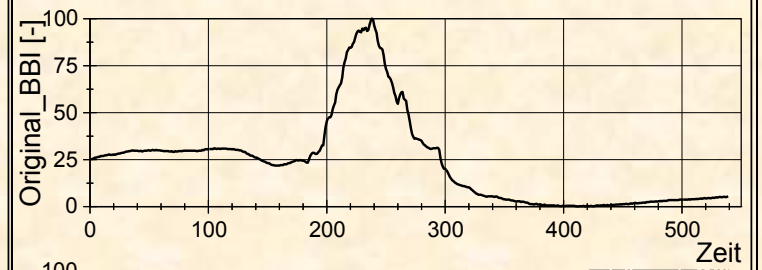

f +/+

Conclusion



- q Deleted angiotensinogen suppresses the vagal counterregulation (pathophysiologic)
- q Transgenic mice differ more from wildtype than male mice differ from female ones
- q Angiotensinogen plays a central role in vagal regulation

2. Example:

Fuzzy-Logic Based Automatic Control of Hemodynamics

Conclusion on fuzzy modeling



- q Fuzzy systems allow modeling of nonlinear cardiovascular interactions (universal approximator)
- q Data Mining: discovery of unknown physiological knowledge
- q Data driven modeling: also learning of noise in data ('rule pruning')
- q Interpretation of dynamical fuzzy systems is quite complex
 - Transformation of the rule bases
 - Automatical text generation
- Universal method for simulation, classification and interpretation